

Review of Reduced and Concessionary Fares in England outside London

House of Commons
30280C

October 19

v1



The TAS Partnership Limited
Passenger Transport Specialists

Quality Assurance

Copyright

Cartography derived from Ordnance Survey mapping is reproduced by permission of Ordnance Survey on behalf of the Controller of HMSO under licence number WL6576 and is © Crown Copyright – all rights reserved.

Other Crown Copyright material, including census data and mapping, policy guidance and official reports, is reproduced with the permission of the Controller of HMSO and the Queen's Printer for Scotland under licence number C02W0002869.



The TAS Partnership Limited
Passenger Transport Specialists

Guildhall House
59-61 Guildhall Street
Preston PR1 3NU
Telephone: 01772 204988
info@taspартnership.com
www.taspартnership.co.uk

Contents

Executive Summary	3
1 Introduction and Objectives	11
1.1 Introduction and Objectives	11
1.2 What do we mean by a Concessionary Fare?	11
1.3 Who is Responsible for What?.....	11
1.4 Our Approach	14
1.5 Exclusions.....	15
1.6 Data Quality and Availability	15
2 The ENCTS Scheme	17
2.1 Introduction	17
2.2 Reimbursement	17
2.3 Enhanced Schemes	18
2.4 Data.....	18
2.5 Enhanced or Statutory Schemes	19
2.6 What Enhancement?	20
2.7 Other Enhancements.....	21
2.8 Enhancements by TCA Type	23
2.9 Discretionary Schemes	25
2.10 The Isles of Scilly	25
2.11 Variations by TCA.....	25
2.12 Cutting Back.....	30
3 Child Fares – Bus.....	33
3.1 Introduction	33
3.2 Age.....	33
3.3 Discretionary Schemes	33
3.4 Multi-Operator Schemes	34
3.5 Commercial Operators.....	36
3.6 Proof of Age Requirement	38

4	Students and 'Young People' – Bus	41
4.1	Overview	41
4.2	Discretionary Schemes	41
4.3	Multi-Operator Tickets	44
4.4	Commercial Operators	45
4.5	Proof of Age Requirement	49
4.6	Scotland and Wales.....	49
5	Group and Family Tickets – Bus.....	51
5.1	Introduction	51
5.2	Maximum Family Size.....	51
5.3	Maximum Group Size	52
5.4	Discount Level.....	52
6	Concessions and Discounts on Other Modes	55
6.1	Introduction	55
6.2	Coach Travel	55
6.3	National Rail.....	57
6.4	Light Rail	60
6.5	Ferries – Isle of Wight	62
6.6	Ferries – Other	63
	Appendix A: Concessionary Fare Legislation	67

Executive Summary

1. Introduction

The Brief

- 1.1 We were asked to review concessionary fares available to all groups of passengers in England outside London. For the purpose of this report, we have defined a concessionary fare as any fare reduced below the level of normal adult fares and offered to particular segments of the market either with or without local authority funding.

Our Methodology

- 1.2 Our primary focus has been on bus services but arrangements on coach, rail services, tramways and ferries are included in the report. This was a desk-based and largely web-focussed exercise. We included website searches of 88 Travel Concession Authorities; the 'Big Five' bus operating groups; the arm's-length municipal operators and major independent operators; a selection of 49 smaller operators; coach operators; tram operators; Train Operating Companies (TOCs) and ferry operators.

The Legislation

- 1.3 The current English National Concessionary Travel Scheme (ENCTS) was introduced on 1 April 2008. ENCTS covers only local bus services. It does not include trams, light rail systems, train services, taxis, ferries or Community Transport, nor does it include cross-border travel into Scotland or Wales.
- 1.4 There are two categories of eligible person for receipt of an ENCTS pass; Older Persons (the age limit was originally set at 60 but now tracks state pension age) and Disabled Persons as defined in the regulations. The holder of an ENCTS pass is entitled to free travel in England (including London) Monday to Friday from 0930 until 2300 and on Saturday, Sunday and Bank Holidays at any time.
- 1.5 Reduced fares for certain categories of rail passenger, including some railcards, are specified in relevant railway legislation.

Enhanced Schemes

- 1.6 Many Travel Concession Authorities (the funders of concessionary fare schemes) provide and fund benefits for passengers beyond the minimum statutory requirements, for instance, available before 9.30am; other modes of travel such as trains, trams, ferries and coaches; Community Transport and Dial-a-Ride services or provide companion passes for disabled persons who

cannot travel independently. Two authorities still maintain eligibility from age 60.

- 1.7 In addition, concessions are offered separately to children and young people, students and families or groups as part of either TCA funded schemes or an operators' commercial incentive to travel.

Travel Concession Authorities, Transport Operators and How the Money Flows

- 1.8 In England, concessionary fares schemes are generally administered by 88 Travel Concession Authorities (TCAs) which fall into three types: Metropolitan Combined Authorities, Unitary Authorities and Shire Counties. Legally, any bus operator accepting an ENCTS pass for travel should be left 'no better off and no worse off' as a result of accepting it. Operators are, therefore, reimbursed by their local TCA simply for revenue forgone – the passenger travelling free of charge is the one who receives the subsidy.
- 1.9 Each TCA calculates its own reimbursement factor, that is, the percentage of the full fare that operators receive. (This is not the case in Scotland and Wales where a nationwide reimbursement factor applies.) The percentage reimbursement differs widely across England and is the subject of much debate. It is, however, notable that as local authority budgets are stretched, reimbursement factors have fallen.
- 1.10 Since 1 April 2011, ENCTS funding has been through the Formula Grant, though enhancements above the statutory requirements are funded locally.

2. Overarching Findings

- 2.1 The clear message from this research is of inconsistency. There is no guarantee based on geography or Local Transport Authority type about any concession being available:
- Beyond the statutory minimum for ENCTS holders;
 - So that disabled ENCTS passholders unable to travel alone can obtain a companion pass;
 - To children
 - ◆ And at what age child fares apply;
 - ◆ Or what discount they will receive (except on National Rail)
 - ◆ Or whether the local authority will fund it.
 - For young people over 16
 - ◆ And if there is, what discount applies or

- To families or groups.
- 2.2 Add to this that operators have no certainty from year to year what proportion of the equivalent fare will be reimbursed.

Financial Sustainability and Equitable Provision

- 2.3 This clearly demonstrates that concessionary travel schemes and commercial discounts offered by transport operators vary significantly and, in many areas, do exceed the minimum statutory requirements. The ENCTS, originally intended to offer an equitable level of provision across England, has often been enhanced by local decisions, making an individual's entitlement something of a postcode lottery.
- 2.4 Over many years, there has been talk of reducing the cost of the national scheme by limiting eligibility, reducing the range of use or by means-testing recipients. However, all the major political parties committed to protecting free bus passes in their 2015 manifestos and the only change has been to the qualifying age for older persons' passes.

3. ENCTS Main findings by TCA type

- 3.1 The key findings for ENCTS were:
- Fewer than half of TCAs extend the use of concessions to modes other than buses;
 - Extensions are often different for disabled and older persons' concessions;
 - 34% of TCAs extend times of availability; and
 - Over half of TCAs issue companion passes.

Metropolitan Combined Authorities

- 3.2 All schemes in metropolitan areas are enhanced for older persons and disabled people:
- 33% offer free travel before 09:30;
 - 83% offer free travel after 23:00; and
 - 50% offer a Companion Pass.

Shire Counties

- 3.3 29% of Older Persons' schemes provide just the statutory minimum compared to 9% of Disabled persons' schemes. Shire Counties offer the following enhancements:

- 29% offer free travel before 09:30;
- 37% offer free travel after 23:00; and
- 63% offer a Companion Pass.

Unitary Authorities

3.4 30% of Older Persons' schemes provide the statutory minimum compared to 19% of Disabled Persons' schemes. Unitary Authorities offer the following enhancements:

- 38% offer free travel before 09:30;
- 45% offer free travel after 23:00; and
- 51% offer Companion Passes.

Main Findings for Enhanced Schemes

3.5 Non-statutory times of validity were broken down into:

- 09:00 start – 18% of TCAs for both older and disabled (but not the same TCAs);
- Post 23:00 finish – 32% of TCAs for older persons and 28% of TCAs for disabled, the most common being valid until end of service; and
- All Day Availability – 6% of TCAs for older persons and 16% of TCAs for disabled.

3.6 In regards to validity on other modes beyond bus, we found:

- Community Transport – 13% of TCAs offer this older persons and 16% for disabled¹;
- Ferries – 6% of TCAs offer this for both older and disabled persons;
- Light Rail – 5% of TCAs offer this older persons and 6% for disabled;
- Local Rail Travel – 16% of TCAs offer this for both older and disabled persons; and
- Taxis – 2% of TCAs offer this for both older and disabled persons.

Main Findings by Passenger Type

3.7 In 2017/18, 90% of passes issued were for older people.

¹ Note this differs significantly from DfT statistics but is based on web information on TCA websites.

- 3.8 Of all schemes for older people, 27% provide the minimum statutory requirements only, 73% offer enhanced entitlement.
- 3.9 Of all schemes for disabled people, 14% provide the minimum statutory requirements only, 86% offer enhanced entitlement.

4. Bus Based Discounted Fares

Child and Young Persons Fare Discount Schemes

- 4.1 There are 23 child and / or young person discounted fare schemes funded by LTAs. The majority of discounted fares are classed as commercial fare discounts given either by individual operators or as part of a multi-operator scheme.
- 4.2 The ages at which child and young person discounts apply vary significantly across England and across bus operators, 57% of all child schemes were classed as 'under 16' with a further 28% valid beyond age 16. 200 of the 278 Young Person schemes were valid for ages 16 to 18. Some areas or operators adopt adult fares at age 11.
- 4.3 Time restrictions are rare for child discounts but some exclude the school peak. In some areas child fares are only available if linked with the possession of some form of pass available locally and thus exclude 'out of area' young people.
- 4.4 29 child schemes offer a flat fare of some description, the most common being a £1 single fare. 492 schemes offer a discount of varying amounts, but the three most common levels for children were:
- 50% discount – 38%;
 - 33% discount – 20%; and
 - 30% discount – 12%.
- 4.5 There are 27 flat fare schemes for Young People but no dominant fare level. 239 schemes offer a discount of varying amounts, but the three most common levels for Young Persons are:
- 50% discount – 24%;
 - 33% discount – 23%; and
 - 25% discount – 16%.

Family and Group Concessions and Discounts

- 4.6 Just under 60% of the multi-person discounted tickets are classed as family tickets with at least one child required to travel in the group. The most common maximum size for families and groups are:
- Family – 2 Adults + 3 Children = 64% of tickets; and
 - Group – 5 People = 47% of tickets.
- 4.7 There is quite a marked difference in the range of discounts offered by family tickets opposed to group tickets. The former is much more concentrated with just under 70% of all tickets offering a discount of between 45% and 60% compared to buying the equivalent individual tickets. For group tickets 50% of all tickets offer a discount of between 50% and 65%.
- 4.8 Only 21% of multi-person discounted tickets have any time restriction for travel.

5. Other Modes of Public Transport

Coach

- 5.1 There is a marked difference in offerings by nationwide coach operators. National Express offers a range of discount Coachcards for Young People, Disabled and Older People which give a third off the full adult fare. Megabus as the new low-cost contender only offers a 10% discount to students who have a TOTEM card.
- 5.2 Of the eight regional coach operators covered:
- Seven offer discounted travel for children;
 - Six offer discounted travel for 16 – 18 year olds;
 - Five offer discount travel for:
 - ◆ Students, older persons aged 60+ and groups or families; and
 - Four offer discounted travel for Young People aged over 18.

National Rail

- 5.3 There are four national statutory, five national voluntary and four local voluntary railcards. All except the brand new 16-17 Saver offer around 1/3 off standard fares. The 16-17 Saver offers 50% discount as its purpose is to extend the age limit of child fares.

- 5.4 Of the nine national railcards:
- three are off peak only,
 - two are not valid in the peak in the South East of England and
 - three have a £12 minimum ticket price in the peak.
- 5.5 Two of the local railcards are off peak only.
- 5.6 There are five discounted season ticket products in the South East of England aimed at university and higher education students. Four train operators additionally offer some kind of discount for students on single or return tickets.
- 5.7 There are four types of group discount tickets which vary between two and nine adults travelling together. Availability is not universal between train operating companies, indeed just over half of the English train operators offer the supposedly national 'GroupSave' product fully.

Light Rail

- 5.8 There are currently six light rail systems in England outside of London. Only two of these systems allow discounted travel for up to the age of 19 without the need for an LTA specific discount card. Sheffield Supertram will only give a 50% discount to children aged 11 and over if they have South Yorkshire PTE Mega Travelpass.
- 5.9 All six systems offer a family ticket, but only two offer a group ticket. Two of the systems vary their price between peak and off peak for the multi-person tickets offered, whilst a third system only offers its family ticket after 09:30 on weekdays (but all day on weekends).

Ferries – Isle of Wight

- 5.10 The ferries between the Isle of White and mainland have been separated from other domestic ferry routes as they have a different nature. Two operators (Red Funnel and Wightlink) provide these services, both offering half fares for children, a 25% to 30% discount for those aged 60+ and various discounts for groups and families. Only Wightlink offers student and disabled persons' discounts.
- 5.11 There are additional discounts available only to Isle of Wight residents. The common one is for residents attending a hospital appointment in Southampton or Portsmouth. Red Funnel additionally offers discounts for Young People and Job Seekers on the Isle of Wight. Wightlink offers a discount to those in low income households.

Ferries - Other

- 5.12 27 ferry operators were identified offering 63 child discount fare schemes, nineteen of the operators provided free travel for certain ages – the most common being under 5s at 37%. Those aged six to eleven are covered by 84% of schemes.
- 5.13 Nine ferry operators offer some sort of discount to ENCTS holders or those aged 65 and over. Eight operators offer a family discount, with two adults and three children the most common group size and 30% the most numerous discount rate.

1.1 Introduction and Objectives

- 1.1.1 The purpose of this document is to review concessionary fares available to all groups of public transport passengers in England outside London. The primary focus has been on bus services, but arrangements on rail services, tramways and ferries are included.
- 1.1.2 A summary of the statutory provision and the legal position in relation to both buses and railways is contained in Appendix A at the end of this report.

1.2 What do we mean by a Concessionary Fare?

- 1.2.1 For the purpose of this report, we define a concessionary fare as any fare reduced below the level of normal adult fares and offered to particular groups of passenger. This includes not only free bus travel for older and disabled people under the English National Concessionary Travel Scheme (ENCTS), but also enhanced validity of ENCTS passes beyond the statutory minimum level in terms of:
- Times of weekday travel;
 - Modes of travel (trains, trams or ferries); or
 - Use of buses not specified as 'eligible services', including Community Transport and Dial-a-Ride services.
- 1.2.2 Beyond this we look at reduced fares offered to four groups of passengers:
- Children (without prejudging at what age child fares cease to be available);
 - 'Young People' (who are sometimes regarded as a different group from children or students);
 - Students (allowing the definition of student to vary); and
 - Families or Groups (again with a loose definition of group size and composition).

1.3 Who is Responsible for What?

- 1.3.1 This report covers two sources of funding, these being public and private sectors. Private funding is where the concession or discount is provided by the operator at its own financial risk – the logic being that the lower fare should encourage greater use which will go some way to offset, or exceed, the potential revenue loss.

ENCTS Public Funding

- 1.3.2 Figure A outlines the standard public funding cycle for the ENCTS concessionary schemes. The grant from central government nominally covers the statutory element, any enhancement will be funded 'locally'. In England the schemes are generally administered by the 88 Travel Concession Authorities (TCAs).

Figure A: ENCTS Funding Cycle

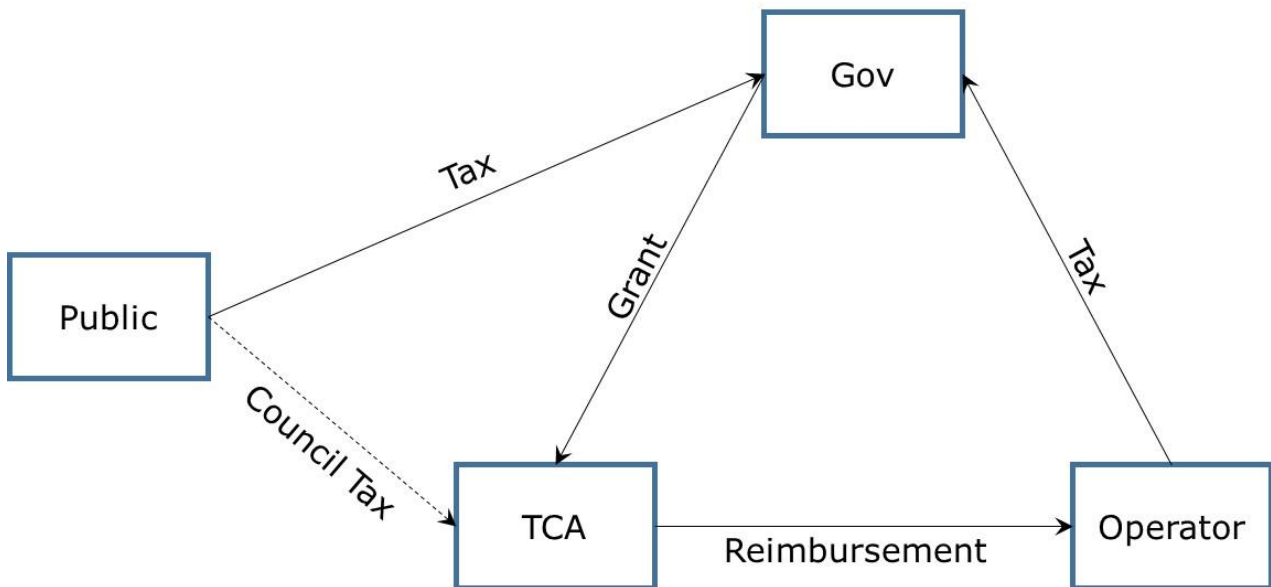

- 1.3.3 Figure B shows how a publicly-funded discount travel scheme compares to a commercial scheme. It should be emphasised that in both cases it is the passenger who receives the subsidy in the form of free or discounted travel and **not** the operator, who in a publicly funded situation simply receives reimbursement for revenue forgone, i.e. the same revenue it would have received if there was no scheme.

Figure B: Public vs Commercially Funded Discount Travel Cycle

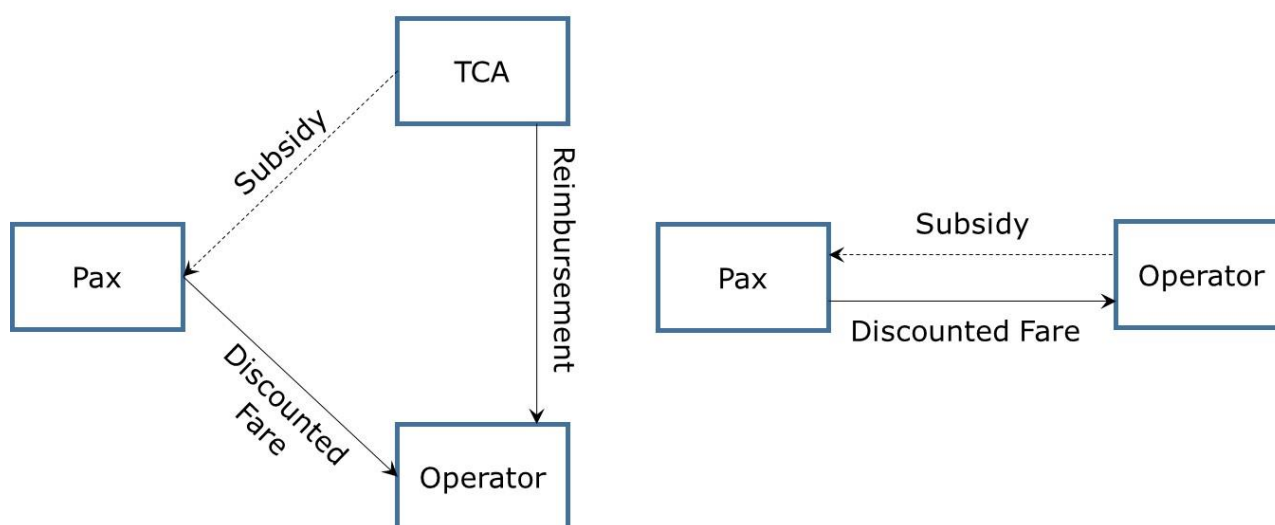

1.3.4 As noted in 1.3.2, public concessionary fare schemes are administered by the 88 TCAs specified for the ENCTS. These TCAs are also Local Transport Authorities (LTAs) with wider public transport duties and, except in Metropolitan areas, local responsibility for highways. TCAs fall into three types:

a) Passenger Transport Executive (PTE) areas – six metropolitan areas which, in three cases, are coterminous with a Combined Authority:

- Greater Manchester (TfGM);
- Merseyside (Merseytravel);
- South Yorkshire (SYPTe);
- Tyne & Wear (Nexus);
- West Midlands (TfWM); and
- West Yorkshire (Metro).

b) Unitary Authorities; and

c) Shire Counties – until 2011 the District Councils within a Shire County acted as the TCAs, District Councils may still fund concessionary fares with the agreement of their 'parent' TCA.

1.3.5 Under the Local Government & Rating Act 1997, Parish Councils also have powers to fund non-bus concessions, including on Community Transport.

1.4 Our Approach

1.4.1 Due to time and resources constraints this was a desk-based and largely web-focussed exercise. Data presented here is correct to September 2019. We included searches of the following websites:

- The 88 (in number) Travel Concession Authorities²;
- The 'Big Five' bus operating Groups by area;
- The arm's-length municipal operators and major independent operators;
- A selection of 49 (in number) smaller operators whose websites included fare details;
- Light rail or tram operators;
- Train Operating Companies (TOCs); and
- Ferry operators.

Some queries were pursued further using a search engine.

1.4.2 The results were summarised in a spreadsheet including:

- LTA covered by the arrangement;
- The name of the scheme;
- The basis of the scheme (child, student, group etc.);
- Applicable age group;
- Percentage discount compared to adult fares;
- Available modes of travel;
- Times of availability;
- Other restrictions, such as the need to have accompanying ID or restricted to residents of a certain area only;
- Medium of ticket issue (paper, office-only; mobile or smartcard) and
- Area of availability.

² Excludes the Isles of Scilly

1.5 Exclusions

1.5.1 We have not included the following in our analysis:

- The issue of tokens or taxi vouchers etc. as a substitute for a concessionary bus pass;
- International travel;
- Internal air travel;
- Free travel for infants under the age of five years³, which is almost universal;
- Discounts for Jobseekers;
- Schemes for those on low incomes;
- Season tickets for travel to and from school or college if such tickets are ONLY valid for the journey to and from school or college:
 - ◆ However, similar tickets which permit travel within a network **outside** school times have been included in the analysis;
- Seasonal fare offers – ‘Kids for a Quid’ in the school holidays and such; nor
- Dog fares:
 - ◆ Which are usually a nominal flat fare (such as 50p), free of charge or a low-priced ‘rover ticket’, although sometimes as an add-on to full fare tickets.

1.6 Data Quality and Availability

- 1.6.1 Information on fares is inconsistent generally, even between different operating areas of the same group. We might, for example, find details and prices for child versions of day and weekly tickets but no, or scant, mention of arrangements for child single fares. We may be able to learn that ‘child discounts’ are valid up to 16 years of age but not what the level of discount is and so on.
- 1.6.2 Smaller operators which are principally coach operators often only have limited information on their bus operations or simply a link to the *Traveline* website which has no fare detail.
- 1.6.3 One of the more difficult aspects is establishing where there is no concession available. If there is, for example, no child fare available it is unusual for any information on tickets to explicitly say so.

³ On some operators the age cap is four or six years old.

- 1.6.4 There is also inconsistency around age limits, even on different pages of the same website. One operator stated that student tickets were available to those aged 16 to 18 in one section; 16 to 19 in another and 16 up to their 19th birthday in a third.
- 1.6.5 Some age limits are also indeterminate in that validity stretches 'until the last day of the term in which the holder's 16th birthday falls' or other equivalent restrictions. We have rounded such age limits to the nearest year.
- 1.6.6 For group or family tickets these normally have a maximum group size. We have calculated the discount by summing individual prices for the maximum group size and composition to act as the 'control' fare.

2.1 Introduction

2.1.1 The current English National Concessionary Travel Scheme (ENCTS) was introduced from 1 April 2008. The basis of the national scheme, administered by upper tier authorities, has remained largely unchanged since its inception, although there have been some changes to the list of eligible services.

2.1.2 ENCTS covers ONLY local bus services. It does not include trams, light rail systems, train services, taxis, ferries or Community Transport, nor does it include cross-border travel into Scotland or Wales.

2.1.3 The ENCTS pass specifies free travel in England (including into and within Greater London) for journeys starting:

- Monday to Friday from 0930 until 2300 (both inclusive); and
- Saturday, Sunday and Bank Holidays at any time.

The norm is for bus ticket machines to allow a couple of minutes' leeway in pass acceptance, thus in practice, 0930 is 0928 or thereabouts.

2.1.4 There are two categories of eligible person for receipt of an ENCTS pass:

- Older Persons – the age limit was originally set at 60 (regardless of gender) but now tracks state pension age;
- Disabled Persons – the definition of 'disabled' is laid down in the regulations and was subsequently amended in relation to War Pensioners.

While there is no distinction in the statutory concession offered, the older persons' and disabled passes are distinguished from each other in appearance.

2.1.5 Where a TCA offers only the statutory minimum, we refer here to a 'Statutory' scheme.

- **In 2017/18 90% of passes issued were for Older Persons.**

2.2 Reimbursement

2.2.1 The subsidy for concessionary fares lies with the user (passholder) and not with the service provider (operator). Operators are not subsidised by concessionary fare schemes. Legally, any bus operator accepting an ENCTS pass for travel should be left 'no better off and no worse off' as a result of accepting the pass for travel. As such, the operators are reimbursed by the local authority for revenue forgone and additional costs incurred such as extra

resources to meet increased demand from passholders and administrative costs.

- 2.2.2 Under ENCTS it is left to each TCA to calculate and advertise its own reimbursement factor, that is, the percentage of the full fare which the operator receives. This is the opposite of the situation in Scotland and Wales where a nationwide reimbursement factor applies. The percentage reimbursement differs widely across England and is the subject of much debate. It is, however, notable that as local authority budgets have been stretched, the reimbursement factors have fallen.
- 2.2.3 Responsibility for reimbursing operators falls with **the TCA where the passenger boards**, regardless of the issuing authority.

2.3 Enhanced Schemes

- 2.3.1 Each TCA is free, under the legislation covering concessionary travel, to independently fund enhancements to ENCTS for its own residents and for journeys commencing within its own boundaries⁴. Within this document we refer to such extensions as 'Enhanced' schemes. These enhancements are principally on the grounds of:
- Eligible age;
 - Times of validity;
 - Modes on which the pass can be used; or
 - Issue of companion passes to some categories of disabled user unable to travel independently.
- 2.3.2 Companion passes are particularly vulnerable to boundary restrictions. A TCA can specify acceptance of these as part of its own scheme, but not in neighbouring authorities. Thus a disabled passholder and companion could legitimately travel free of charge into a neighbouring authority, but the companion would have to pay a fare on the return trip if the companion pass is not accepted by the destination authority.

2.4 Data

- 2.4.1 Data presented below has been taken from the relevant Concessionary Fares webpage of each TCA. Some of the findings are at variance with the figures shown in the DfT's Concessionary Travel Statistics – England 2017/18. While there will have been changes to arrangements since 2017/18 we suspect, particularly with regard to validity on CT services, this is more an issue of failure of information.

⁴ And also in neighbouring authorities by agreement.

Table 1: TCA Websites vs. DfT 2017/18 Statistics

Enhancement	TCA Websites	DfT	Explanation
Variation to Time	41	70	Websites are quite specific. DfT figure may include those which exempt specific journeys.
Companion Passes	49	53	Change over Time
CT or Dial-a-Ride	14	44	Paucity of information on concessionary fares pages
Park & Ride	6	29	TCAs tend not to mention Park & Ride if it is not excluded

2.4.2 Note that the legal basis for excluding Park & Ride services is not always clear, and will depend on local circumstances. The website findings may therefore reflect a presumption that Park & Ride services are included in ENCTS.

2.5 Enhanced or Statutory Schemes

2.5.1 Figure C shows a summary of TCAs offering Enhanced or Statutory provision. There are far more Enhanced schemes than Statutory – particularly for Disabled passes.

Figure C: Proportion of Enhanced and Statutory Concessionary Schemes

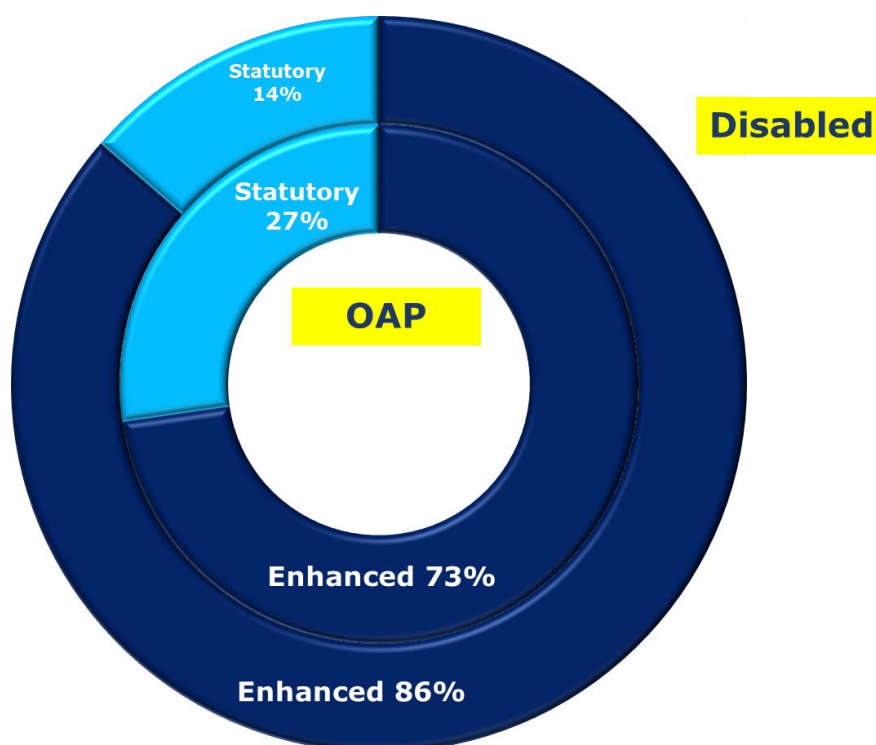

- 2.5.2 Table 2 shows the TCAs by type and whether they have Enhanced or Statutory schemes for older people. None of the Metropolitan areas has a Statutory scheme and the shires and unitaries have a similar proportion of TCAs which offer Statutory schemes at around 30% of TCAs.
- 2.5.3 Table 3 repeats the analysis for disabled pass eligibility. None of the Metropolitan areas and only three of the shires offer a simple Statutory disabled scheme. Some 19% of unitary authorities offer only a Statutory disabled scheme.

Table 2: Older Persons' Concessions – Statutory or Enhanced by Type

	Met	Shire	Unitary	All
Enhanced	6	25	33	64
Statutory	0	10	14	24
Total	6	35	47	88
% Statutory	0%	29%	30%	27%

Table 3: Disabled Concessions – Statutory or Enhanced by Type

	Met	Shire	Unitary	All
Enhanced	6	32	38	76
Statutory	0	3	9	12
Total	6	35	47	88
% Statutory	0%	9%	19%	14%

2.6 What Enhancement?

2.6.1 A number of different enhancements apply to ENCTS:

- **Age** – Only two TCAs now offer passes below state pension age (Merseyside and West Midlands) both of whom allow free local travel at 60.
- **Other Modes** – Figure D shows the number of schemes extended to include non-bus modes. In most cases the extension allows a reduced fare rather than free travel, although most validity on trams allows free travel.
- **Morning Start Time** – Figure E shows the summary of morning start times with 24% of Older Persons' and 34% of disabled passes allowing travel before 0930 Monday to Friday:
 - ◆ Note there are more TCAs which allow pass use on specific journeys starting before 0930, particularly in rural areas. These have not been included above.

- **Evening End Time** – Figure F shows the summary of late evening validity with 38% of Older Persons’ and 44% of Disabled passes being valid after 2300. In a few cases evening validity extends through to early the following day.
- **47 of 88 TCAs (53%) limit pass use to the Statutory 0930 to 2300**
- **Companion Passes** – 56% of TCAs offer companion passes.

2.7 Other Enhancements

2.7.1 There is a variety of other enhancements to ENCTS validity, including:

- Discount on the purchase of a Senior Railcard:
 - ◆ Sometimes a Senior Railcard is offered as an alternative to an ENCTS pass;
- Discount on National Express coaches;
- All TCAs that border Scotland or Wales allow cross-border travel, as do three which have no border; while two schemes permit limited journeys wholly within Wales;
- District-specific enhancements;
- Exemption from bridge tolls;
- Vouchers for use on other modes.

2.7.2 Acceptance of ENCTS on the London bus network is universal and available all day, although the technological incompatibility between TfL’s ticket machines and the ITSO software means recording of use is different.

Figure D: Extension of ENCTS Validity to Other Modes

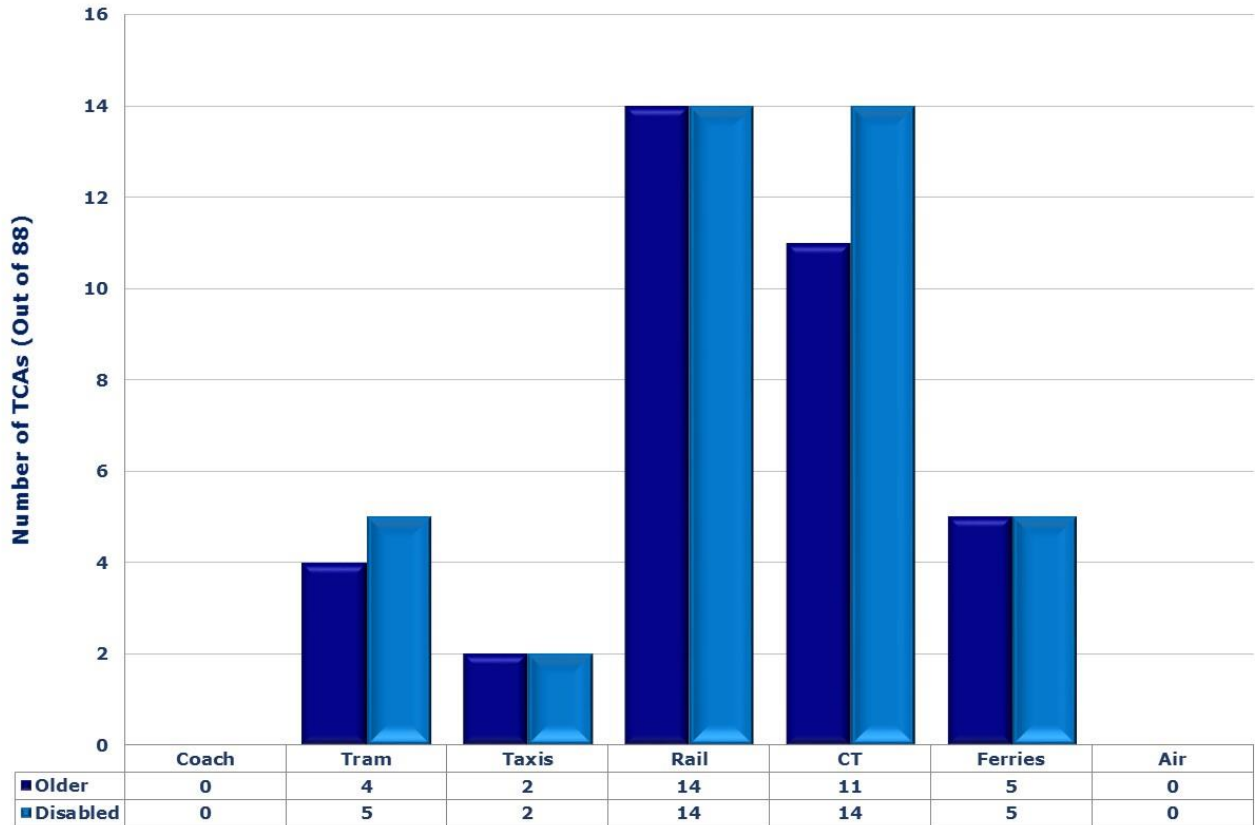

Figure E: Monday to Friday Start Time

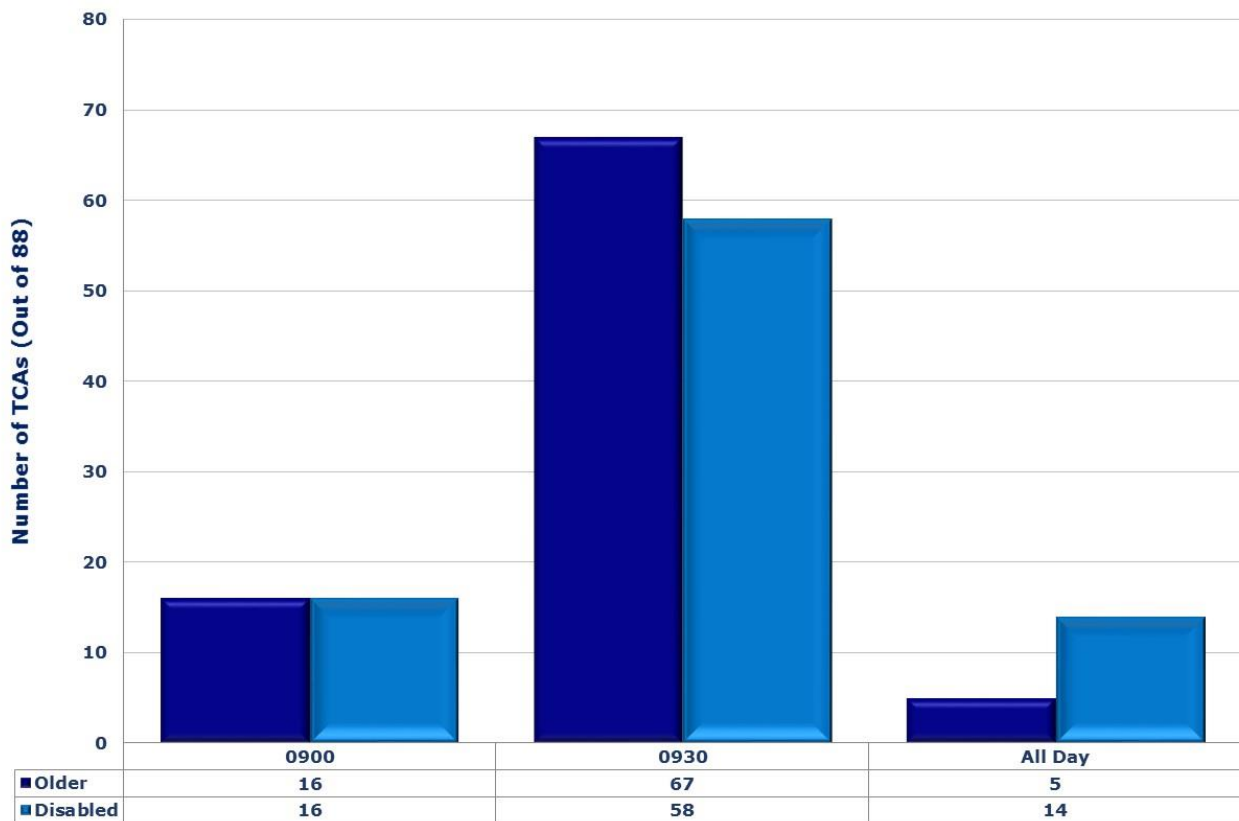
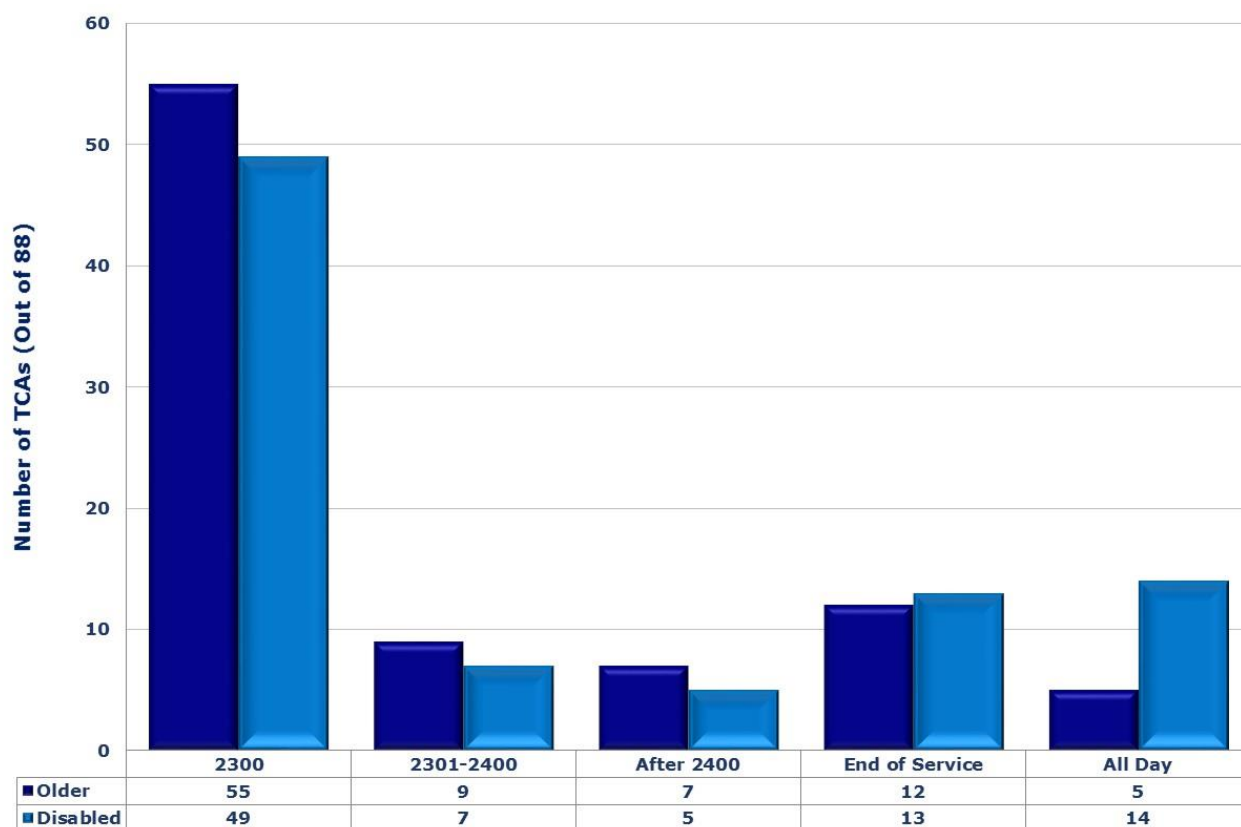

Figure F: Monday to Friday End of Validity



2.8 Enhancements by TCA Type

- 2.8.1 The enhancements offered to the basic ENCTS scheme differ by area type. In Figure G the variation in morning time limits is shown, with unitary authorities most likely to offer such a variation and shires least likely. The shires, however, are most likely to offer service-specific exemptions in rural areas. Hampshire, for example, has a long list of exemptions⁵).
- 2.8.2 Figure H shows the equivalent for extensions beyond 2300. All but one of the Metropolitan areas allows travel beyond 2300 against only 37% of shires. Overall, TCAs are more likely to allow travel after 2300 than before 0930.
- 2.8.3 Figure I shows variation in the issue of companion passes. While only half of Metropolitan and Unitary TCAs issue companion passes, no fewer than 63% of shires do so.

⁵ <https://www.hants.gov.uk/transport/publictransport/buspasses/olderpersonsbuspass/checkservices>

Figure G: Variation to Morning Time Limit by TCA Type

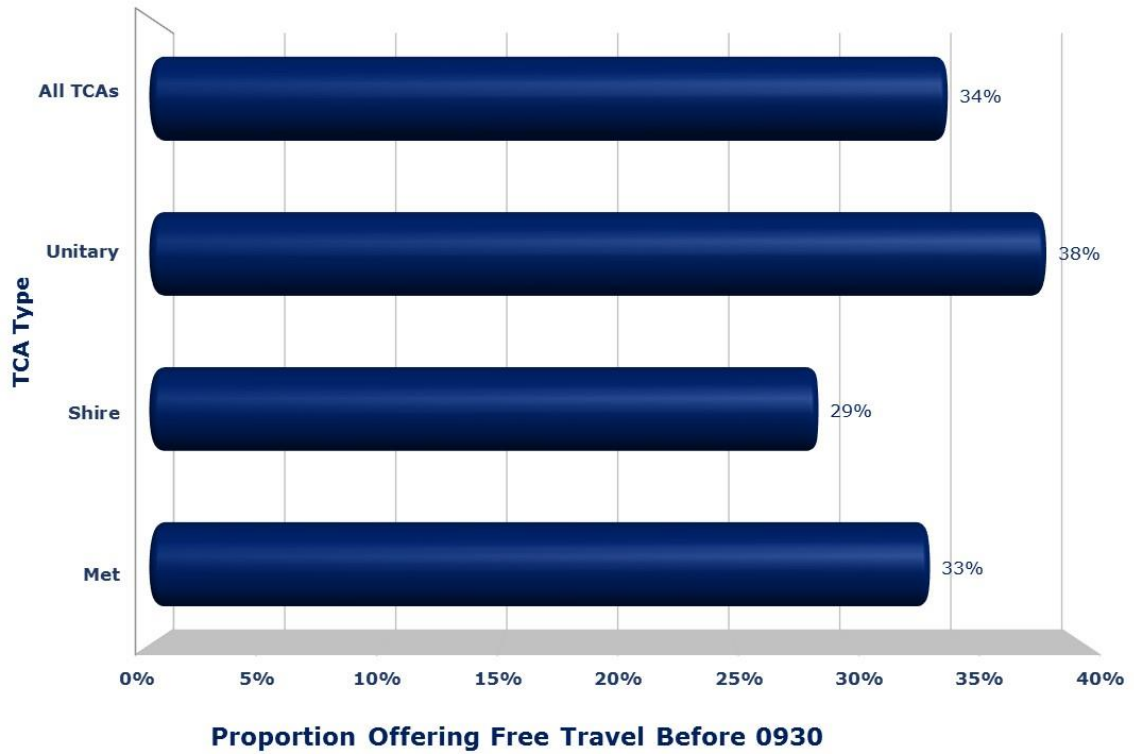

Figure H: Variation to Evening Time Limit by TCA Type

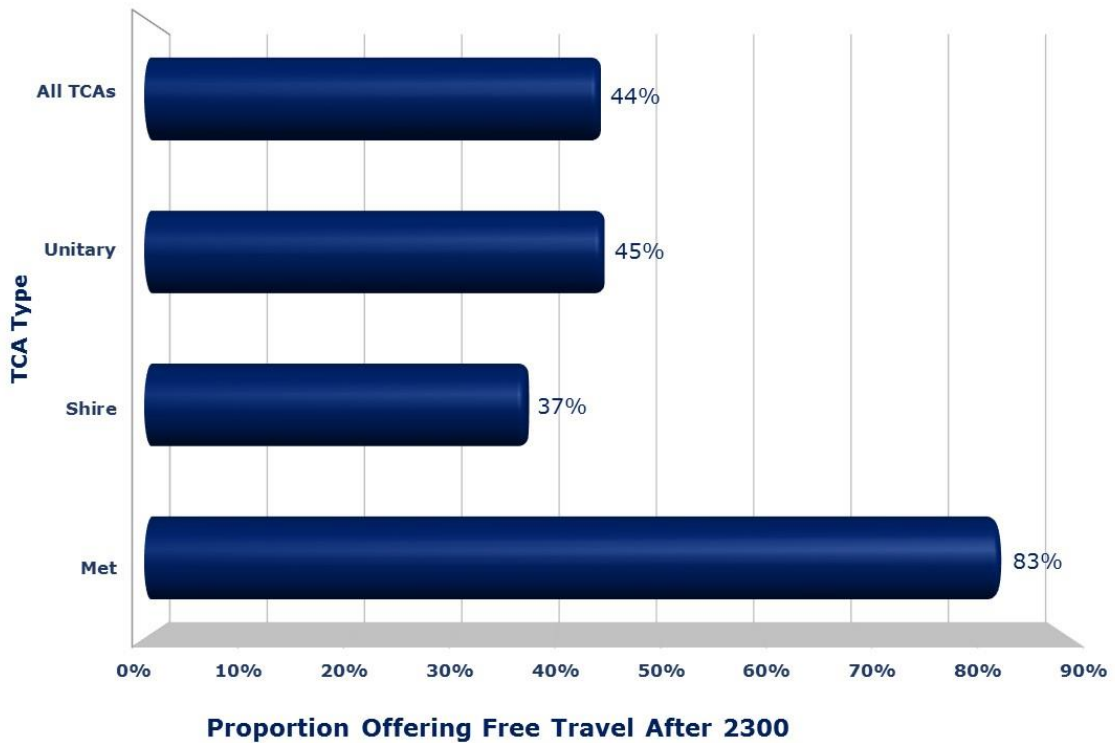
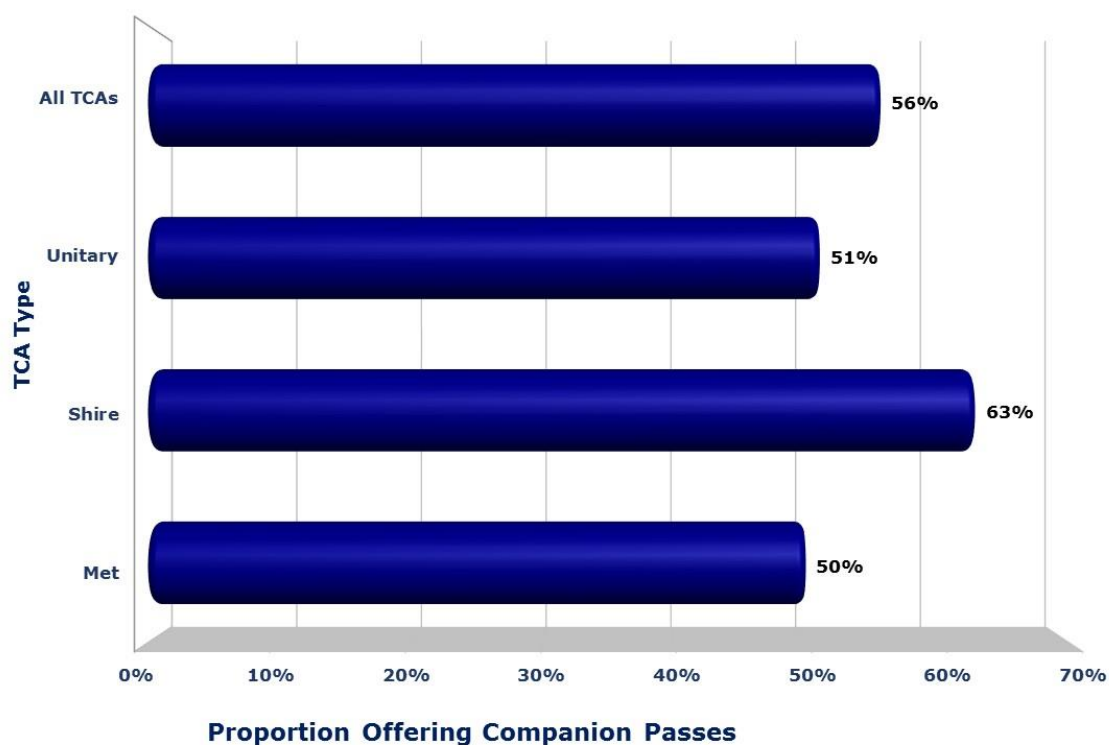

Figure I: Issue of Companion Passes by TCA Type



2.9 Discretionary Schemes

2.9.1 In addition to Statutory and Enhanced schemes, the groups covered by ENCTS can be offered other discretionary concessionary fares. These may involve payment of a fixed fee for a set concession, being offered *instead of* the right to be issued with an ENCTS pass or may be offered in addition to the ENCTS pass. For example from 2020 TfGM will charge £10 to any Greater Manchester ENCTS card holder who wishes to have the Metrolink tram discretionary element.

2.10 The Isles of Scilly

2.10.1 We have not included the Isles of Scilly in the above analysis as, although it distributes ENCTS passes, these cannot be used on any form of transport on the Isles. However residents of any island which isn't St Marys who are of state pension age or are classed as disabled under ENCTS guidelines can apply for 52 single fare vouchers for inter-island boat travel.

2.11 Variations by TCA

2.11.1 Figure J to Figure M show the variation in Statutory and Enhanced times of validity. Figure N shows the variation in issuing of companion passes – some

TCA's offer companion passes as a consortium; for example, a Tyne and Wear companion pass is also valid in County Durham, Darlington and Northumberland and vice versa.

Figure J: ENCTS Older Persons Permitted Mon-Fri Start Time by TCA⁶

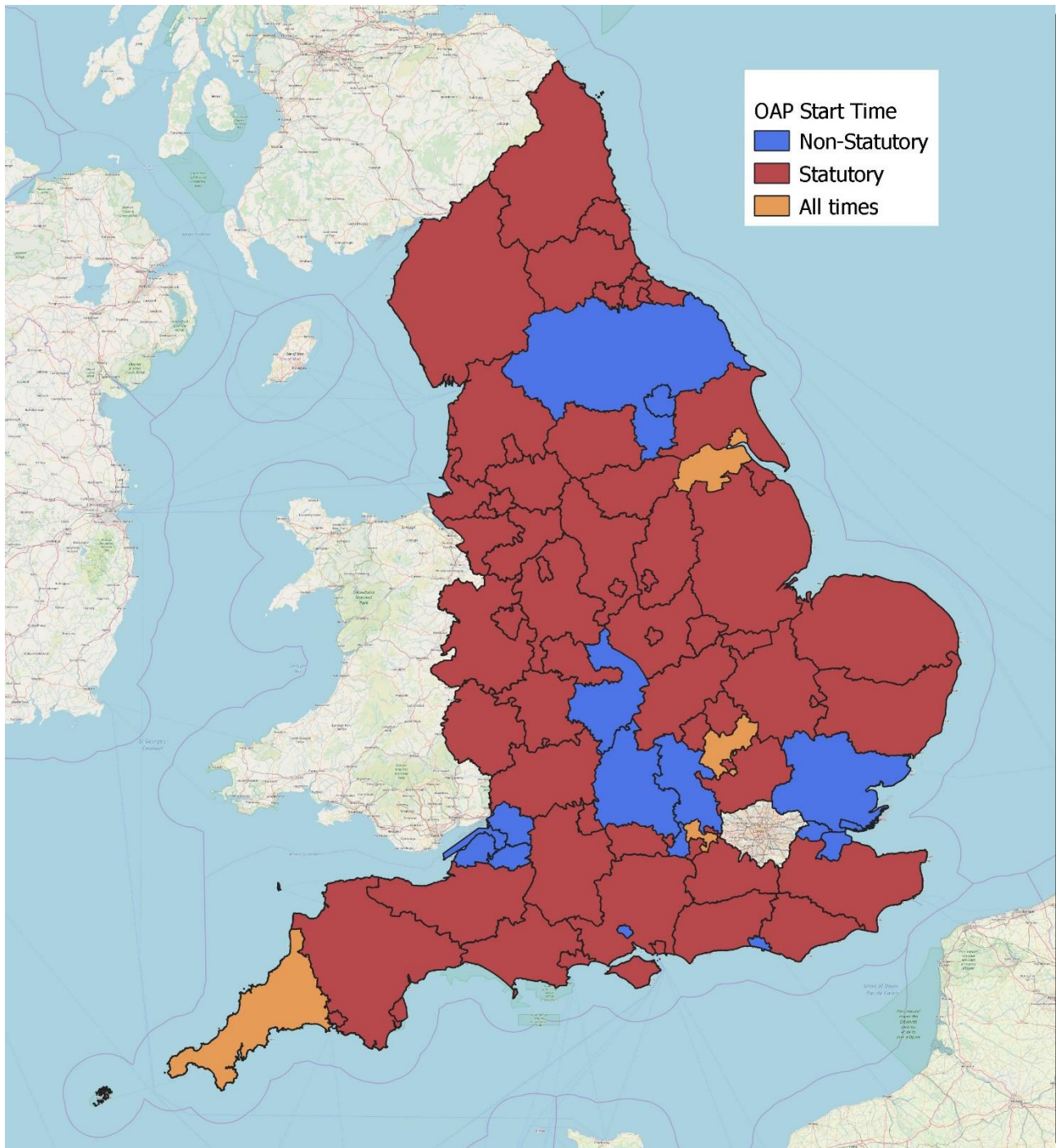

⁶ Note that all 'non-statutory' start times are 0900 in practice; Service-specific exemptions are not included.

Figure K: ENCTS Older Persons Permitted Mon-Fri End Time by TCA

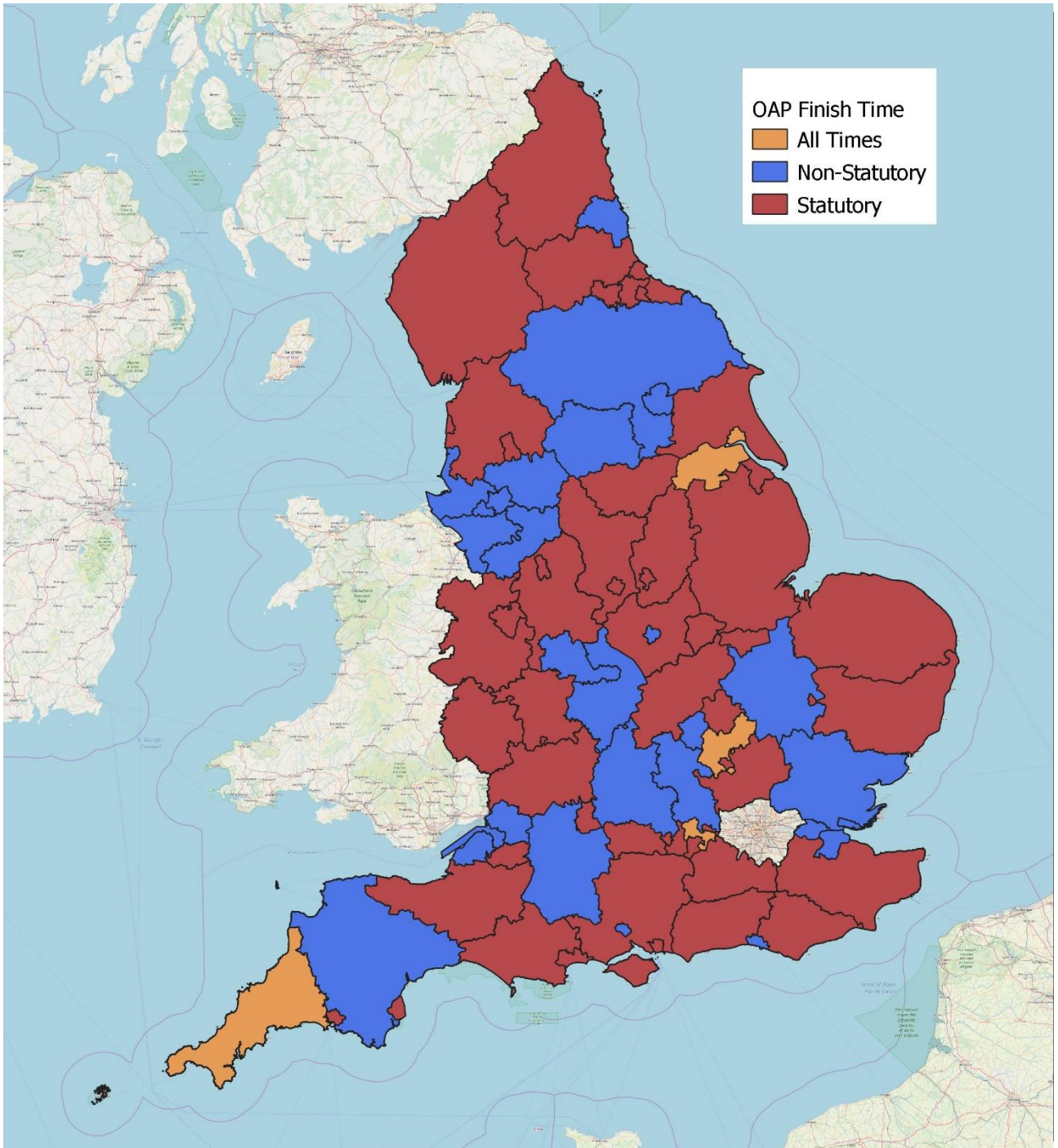

Figure L: ENCTS Disabled Persons Permitted Mon-Fri Start Time by TCA

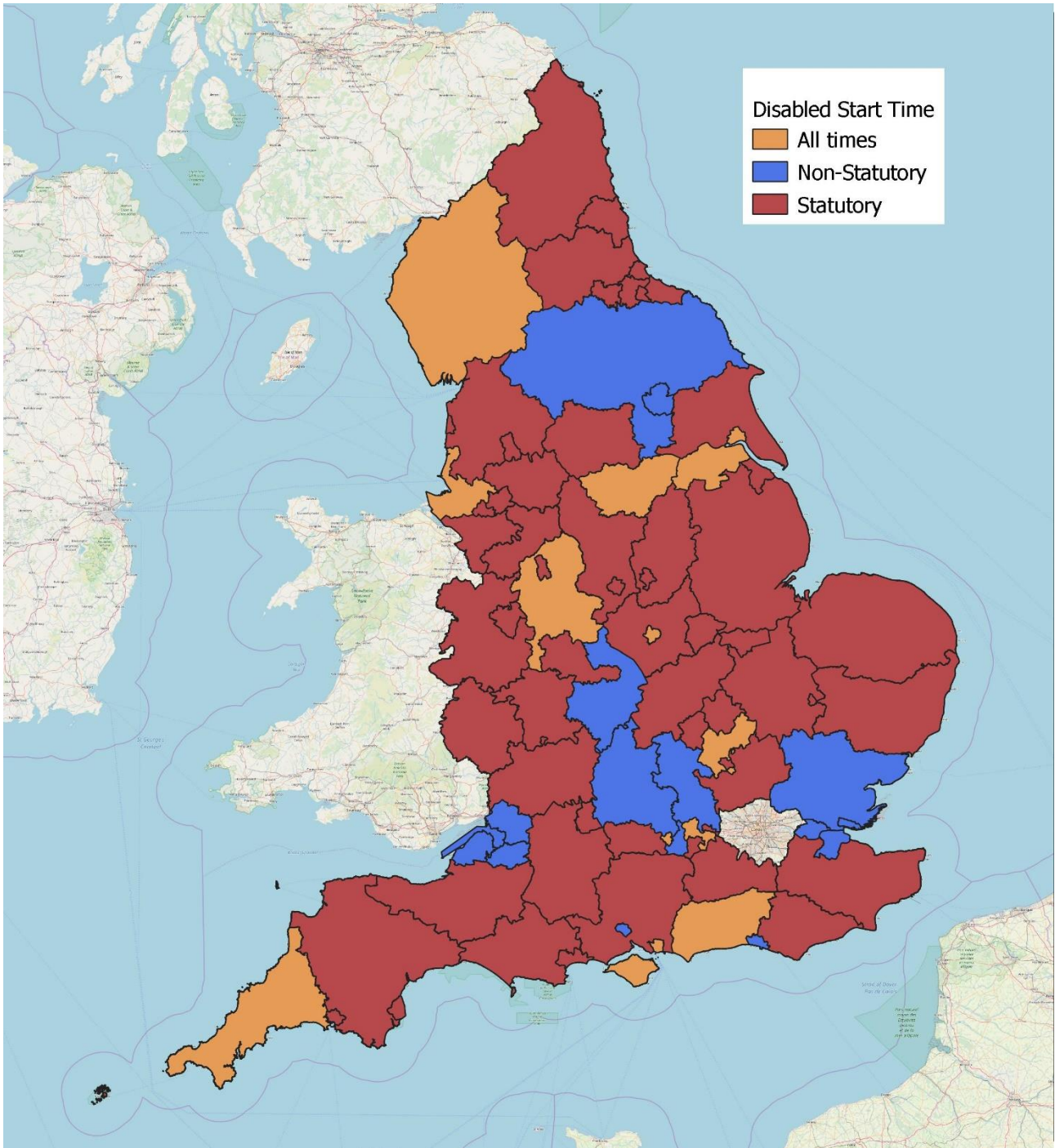

Figure M: ENCTS Disabled Persons Permitted Mon-Fri End Time by TCA

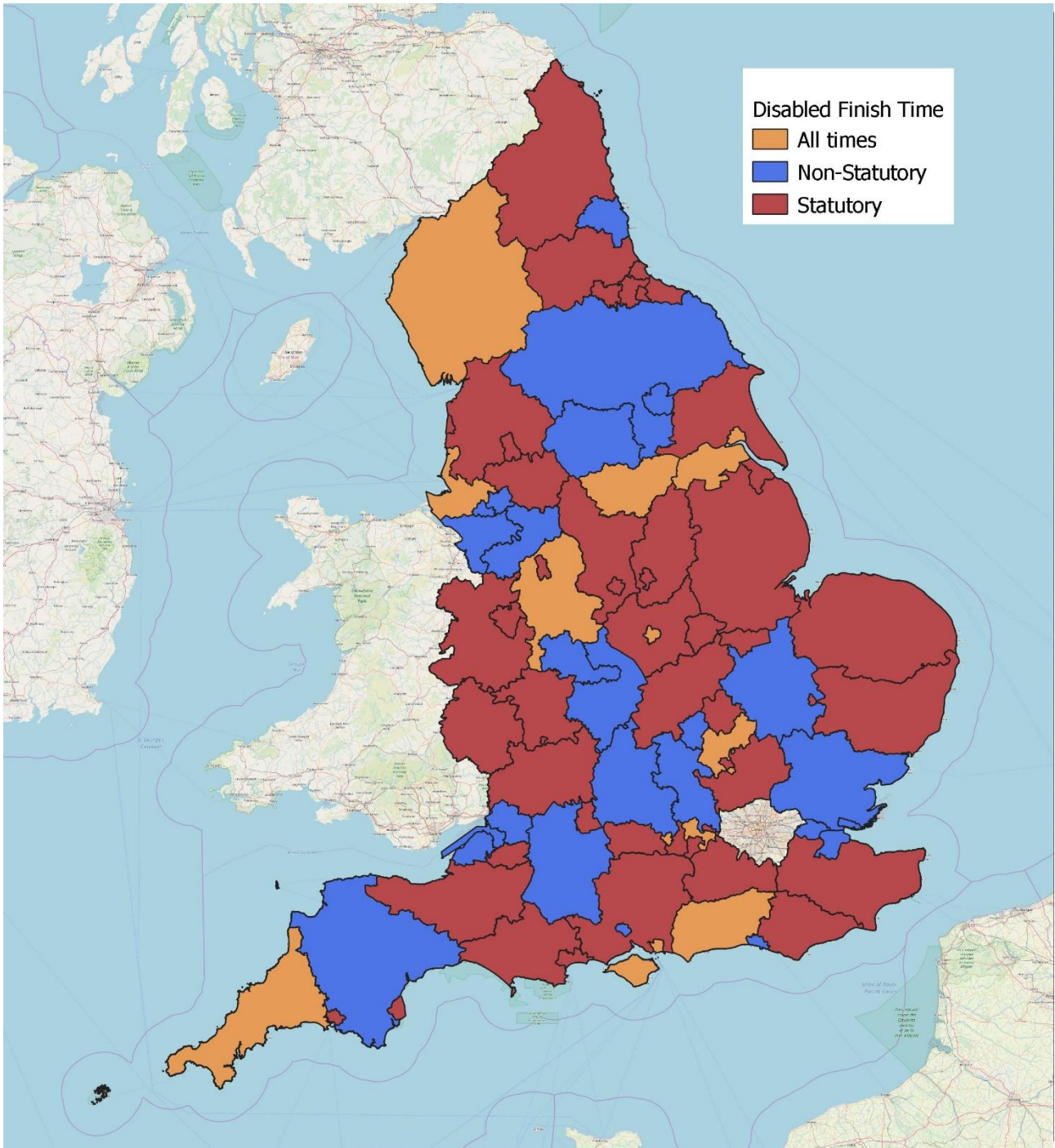
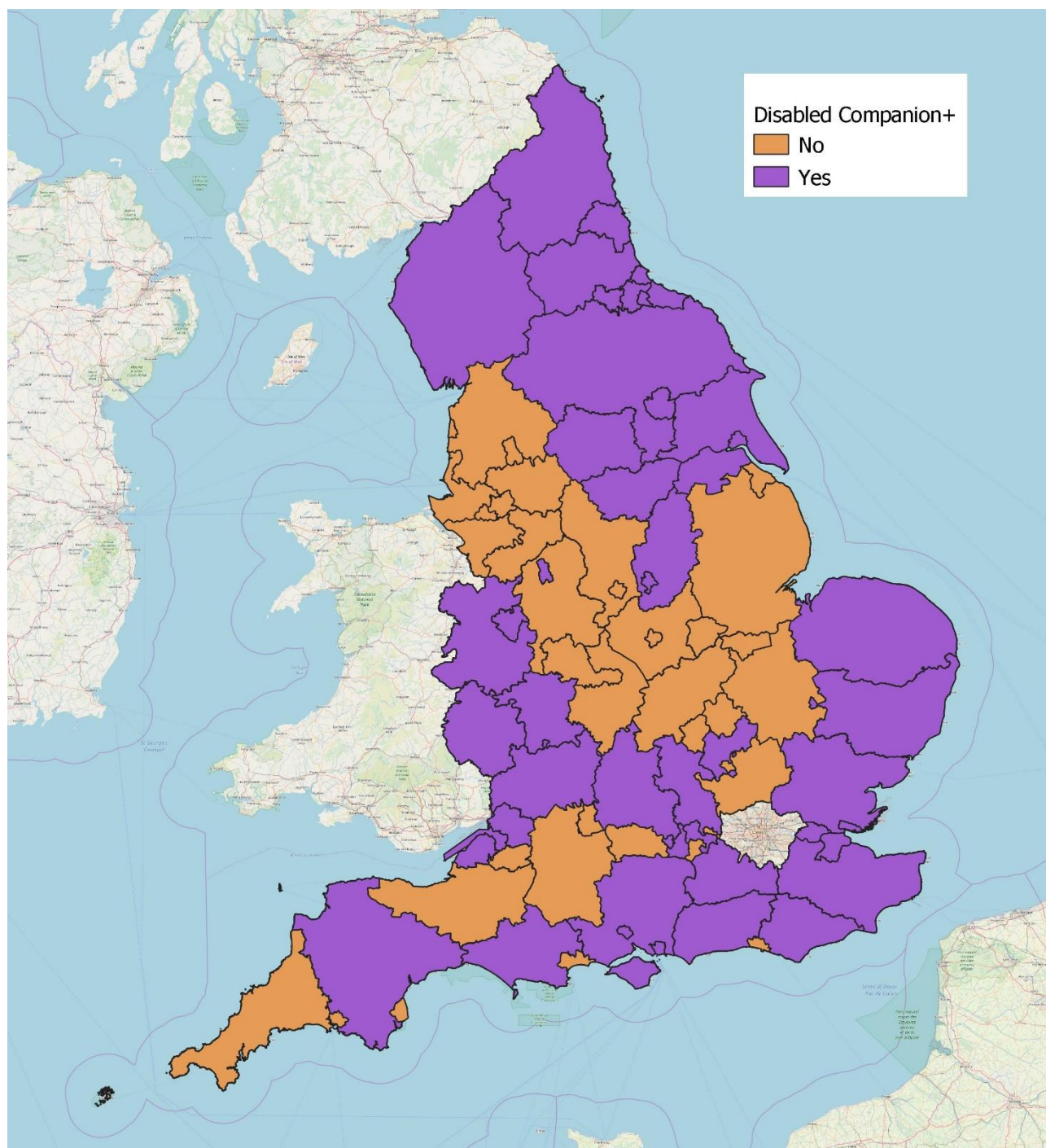

Figure N: ENCTS Availability of Companion Passes by TCA



2.12 Cutting Back

2.12.1 The Local Government Association estimates that outlay on discretionary concessionary fare elements has reduced by £30m between 2014/15 and 2017/18 financial years⁷. Examples of TCAs saving money on reimbursement include:

⁷ <https://www.route-one.net/news/bus-patronage-in-england-down-by-7-in-five-years/> accessed 18/09/2019

- Stoke-on-Trent City Council (2012) reducing the time of validity to statutory to save £100k per year;
- Luton Borough Council (2013) changing the time of validity from all day to statutory and withdrawing validity on South Beds Dial-A-Ride and Shop-mobility services to save £330k per year;
- Staffordshire County Council (2018) reducing the time of validity to statutory to save £100k per year;
- Northamptonshire County Council (2019) withdrawing subsidised bus services to save £323k per year in concessionary fare reimbursement.

3.1 Introduction

3.1.1 This section looks at bus fares and discounts offered to children. These fall into two groups:

a) Discretionary Schemes – funded or reimbursed by LTAs:

- ◆ Note that it is not abundantly clear which ticket schemes for children and young people receive financial support from LTAs. Our separation below and in section 4 is based at least partly on past knowledge.

b) Commercial Discounts:

- ◆ We have looked at Multi-operator tickets separately, but the assumption is that these are commercial initiatives.

3.1.2 The assumption that children automatically receive half fare until their 16th birthday is false. The age at which children become liable to pay adult fares varies between eleven and twenty five years of age, plus in some cases there is no child fare available at all. In addition, the level of discount offered varies considerably. For simplification we have kept our definition of child here as under 16, with any scheme that also applies to those aged over 16 repeated in section 4 which deals with fares for 'Young People'.

3.1.3 The data here relate only to tickets that are generally available and cover at least part of a network. There are many non-statutory school services which offer special prices but only on bespoke services to and from school. Such arrangements are excluded from the analysis.

3.2 Age

3.2.1 Whilst it can be said that in general child fares cover those aged 5 to 15 it is not universal. Free travel for those aged under 5 is almost an unwritten law, however operators do vary how many under-5s can travel free with an adult.

3.2.2 In the same way there is a level of overlap between child and young person. This is because some schemes cover those aged 5 – 15 (shown as under 16) whilst others cover 5 – 18 or older.

3.3 Discretionary Schemes

PTEs (Metropolitan Areas)

3.3.1 As well as a child version of some of the multi-operator tickets (organised by the Ticketing Companies) the PTE schemes in Table 4 offer additional

concessions to children. The passes only need to be purchased once rather than every year.

Table 4: PTE Schemes – Child

LTA	Scheme	Age	Concession	Transport Modes	Cost of Pass
Greater Manchester	Igo Card	11-15	50% Discount	Bus and Tram	£10
Tyne & Wear	U16 Pop	Under 16	£0.60 Single, £1.10 Day	Bus, Tram, Ferry and Rail	£5
South Yorkshire	MegaTravel Pass	Under 16	£0.80 Single	Bus and Tram	n/a

Non-PTE

3.3.2 Seven non-PTE LTAs currently have discretionary schemes which are shown in Table 5. Where the scheme includes those aged 16 and over, the age is left blank or there is no upper limit shown.

Table 5: Non-PTE Schemes – Child

LTA	Scheme	Age	Concession	Transport Modes	Cost of Pass
East Sussex	Freedom Week		£17 Week	Bus	n/a
Hertfordshire	Hertfordshire Saver Card	11+	50% Discount	Bus	£25 p.a.
Kent	Travel Saver	12-16	Unlimited Travel	Bus	£360 p.a.
Kingston-Upon-Hull*	KAT Card		20% Discount	Bus	n/a
Medway	Medway Youth Pass	Under 16	Child Fare before 09:00	Bus	£10
Milton Keynes	All-in-1		£1 Single, £8.50 Week, £27 Month	Bus	£5
York	YOZone	Under 16	Discount Card	Bus	n/a

*Also valid in parts of East Riding of Yorkshire which border Hull

3.4 Multi-Operator Schemes

3.4.1 These are child versions of multi-operator tickets. Some multi-operator ticketing schemes, such as Connecta in Worcestershire or Solent Go in Hampshire, Portsmouth and Southampton, do not have child discounted versions. Table 6 includes the PTE organised multi-operator schemes that have child versions but are different from the child concession subsidised by the LTA.

Table 6: Multi-Operator Schemes – Child

LTA	Scheme	Age	Price / Discount	Transport Modes	Restrictions?
Bath and North East Somerset	AvonRider Child	Under 16	25%	Bus	n/a
Bournemouth, Christchurch & Poole	Get About Child	Under 16	40%	Bus	n/a
Brighton & Hove	Discovery Child	Under 16	20%	Bus	n/a
Bristol, City of	AvonRider Child	Under 16	25%	Bus	n/a
Cornwall	Skipper Child		25%	Bus	Plymouth Urban Area
Derby	Spectrum Child	Under 16	33%	Bus	05:00 – 23:59
Derbyshire	Wayfarer Child	Under 16	50%	Bus and Rail	Rail post 09:00 Weekdays
Devon	Skipper Child		25%	Bus	Plymouth Urban Area
East Sussex	Discovery Child	Under 16	20%	Bus	n/a
Essex	Borough Child	Under 16	30%	Bus	Colchester Borough Area
Hampshire	Discovery Child	Under 16	20%	Bus	East Hampshire Only
Hertfordshire	Hemel Hempstead Busnet Child	11+	40%	Bus	Savercard Needed
	St Albans Busnet Child	11+	40%	Bus	Savercard Needed
	Watford Busnet Child	11+	40%	Bus	Savercard Needed
	Welwyn Hatfield Busnet Child	11+	40%	Bus	Savercard Needed
Leicester	Flexi Child	Under 16	20%	Bus	Not Park & Ride
Kent	Discovery Child	Under 16	20%	Bus	n/a
Medway	Discovery Child	Under 16	20%	Bus	n/a
Merseyside	My Ticket		£2.20 Day	Bus	n/a
	Young Person Solo		50%	Bus	n/a
	Young Person Trio		50%	Bus, Rail & Ferry	n/a
	Young Person Saveaway		50%	Bus, Rail & Ferry	After 09:30 Weekdays
Norfolk	Fusion Child	Under 16	30%	Bus	Norwich Urban Area
North Somerset	AvonRider Child	Under 16	25%	Bus	n/a

LTA	Scheme	Age	Price / Discount	Transport Modes	Restrictions?
Nottingham	Robin Hood Child		40%	Bus, Tram & Rail	n/a
Nottinghamshire	Robin Hood Child		40%	Bus, Tram & Rail	Nottingham Urban Area
Oxfordshire	SmartZone 18 & Under		20%	Bus	Oxford Urban Area
Plymouth	Skipper Child		25%	Bus	n/a
South Gloucestershire	AvonRider Child	Under 16	25%	Bus	n/a
Southend-on-Sea	Octopus Child	Under 16	25%	Bus	n/a
Staffordshire	Smart Child	Under 16	25%	Bus	North Staffordshire
Stoke-on-Trent	Smart Child	Under 16	25%	Bus	n/a
Surrey	Discovery Child	Under 16	20%	Bus	n/a
Swindon	YP TravelPass		25%	Bus	n/a
West Midlands CA	n-network Child	Under 16	33%	Bus, Tram & Rail	After 09:30 Weekdays
West Sussex	Discovery Child	Under 16	20%	Bus	n/a
West Yorkshire	Child M-Card	Under 16	50%	Bus & Rail	n/a
Wiltshire	YP TravelPass Plus		25%	Bus	Swindon Urban Area
York	All York Child	11-16	50%	Bus	After 09:00 Weekday

3.5 Commercial Operators

3.5.1 This section looks at discounts offered commercially by operators. Such schemes are far more numerous and apply to a much higher proportion of passengers.

Age

3.5.2 Figure O below shows the various age categories used by commercial operator schemes. Over 80% of the operators had a scheme covering those aged 5 to 15.

Figure O: Age Range – Child Fare Schemes

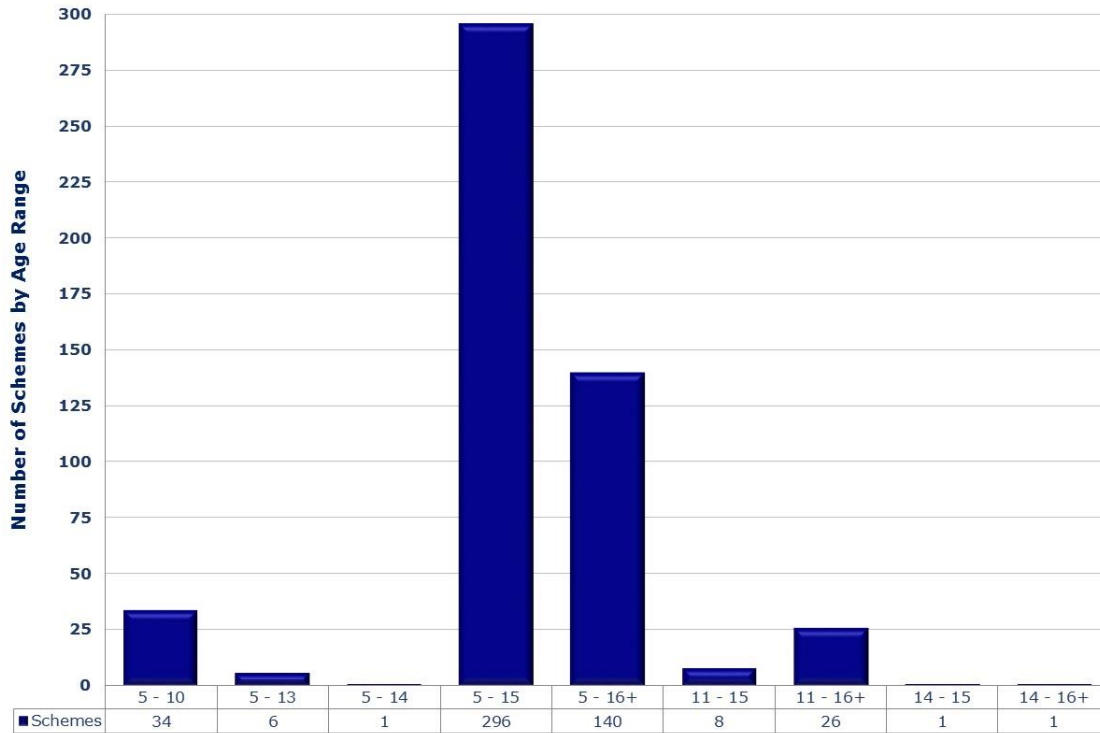

Discount

3.5.3 Whilst age limits are fairly uniform for commercial child fares, the level of discount certainly is not. As Figure P shows, half fare is the most common discount, but applies to fewer than forty per cent of schemes.

Figure P: Discount Level – Child Fare Schemes

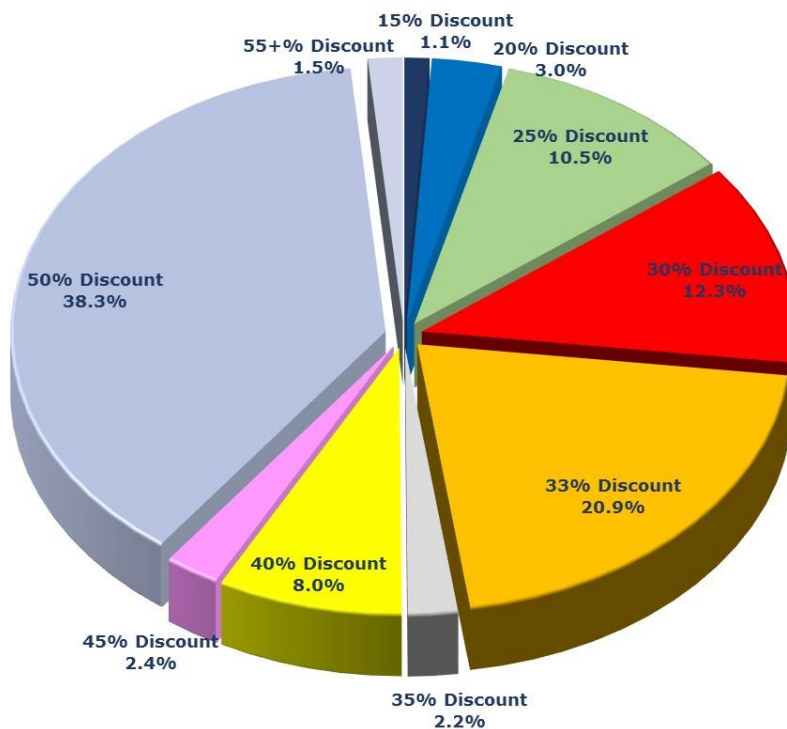

Flat Fare

3.5.4 A number of commercial operators offers a flat fare scheme instead of or alongside a percentage discount scheme for child tickets. This is only counted where there is no equivalent adult product (e.g. there is no adult flat single fare). These tend to be single journey fares; Figure Q shows the distribution of them by price, however the following other schemes were also found:

- Return Fare:
 - ◆ 1 @ £2.75, 2 @ £3.00 and 1 @ £3.50;
- 10 Journey Tickets:
 - ◆ 1 @ £10 and 1 @ £14; and
- One Annual Ticket at £750.

Figure Q: Distribution of Commercial Flat Fare Singles

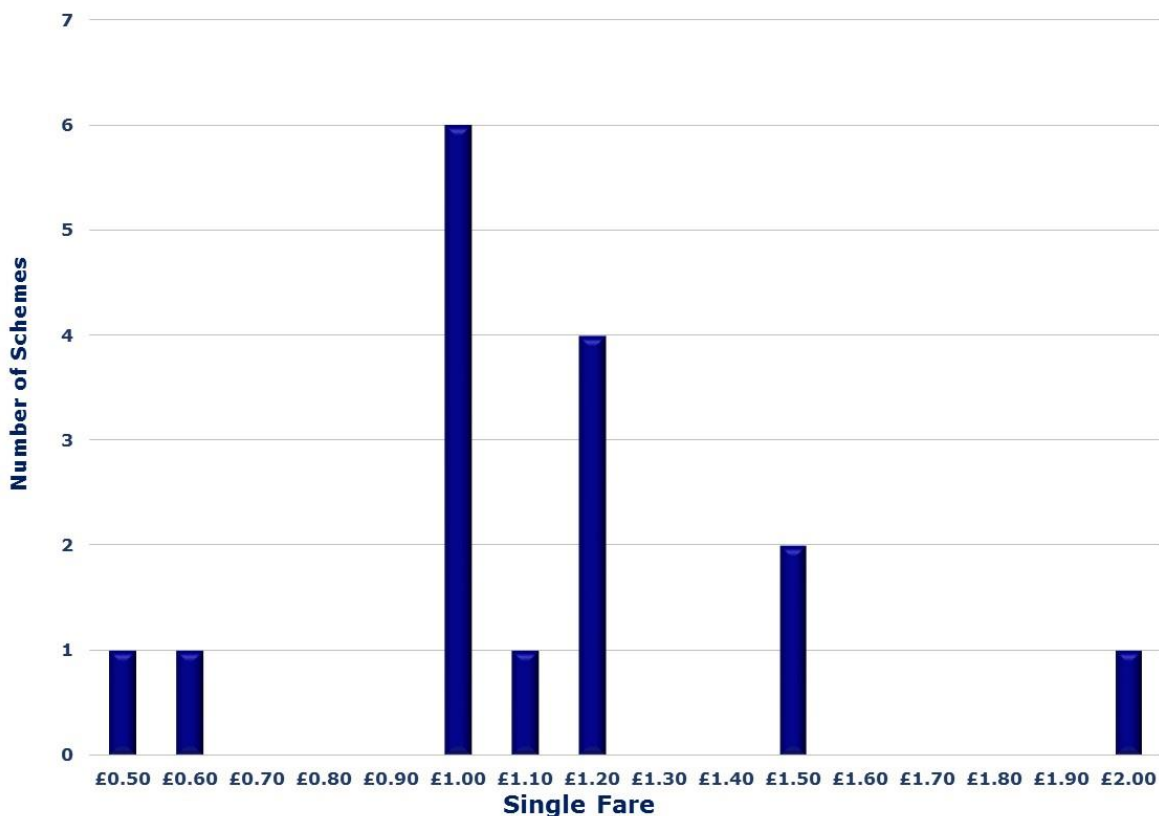

3.6 Proof of Age Requirement

3.6.1 As can be seen from Figure R, around a quarter of schemes require some sort of proof of age at the point of purchase. ID Card needed represents those tickets that can be purchased from the driver but require a proof of age to do so. Smartcard, m-ticket and flashpass (paper tickets shown to the driver) all

need proof of age either when purchasing from the travel office or when setting up an online account.

Figure R: Proportion of Schemes Requiring Proof of Age – Child Fares

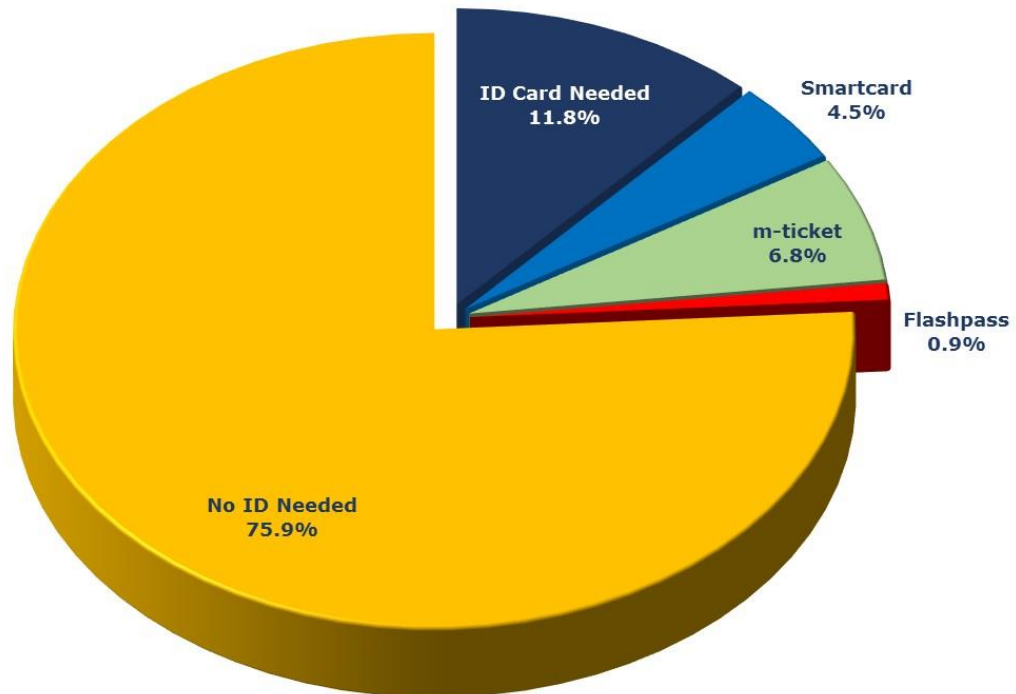

4.1 Overview

4.1.1 As mentioned in 3.2.2 there is an overlap between child and young person schemes. For 'Young Person' we have taken it as any scheme which is available to those aged 16 and over, even if it is the same as the child fare scheme.

4.2 Discretionary Schemes

4.2.1 Figure S highlights the areas where Discretionary Young Persons' travel schemes covering bus travel are in operation along with those areas which have recently withdrawn them.

Figure S: Current and Withdrawn Discretionary YP Schemes

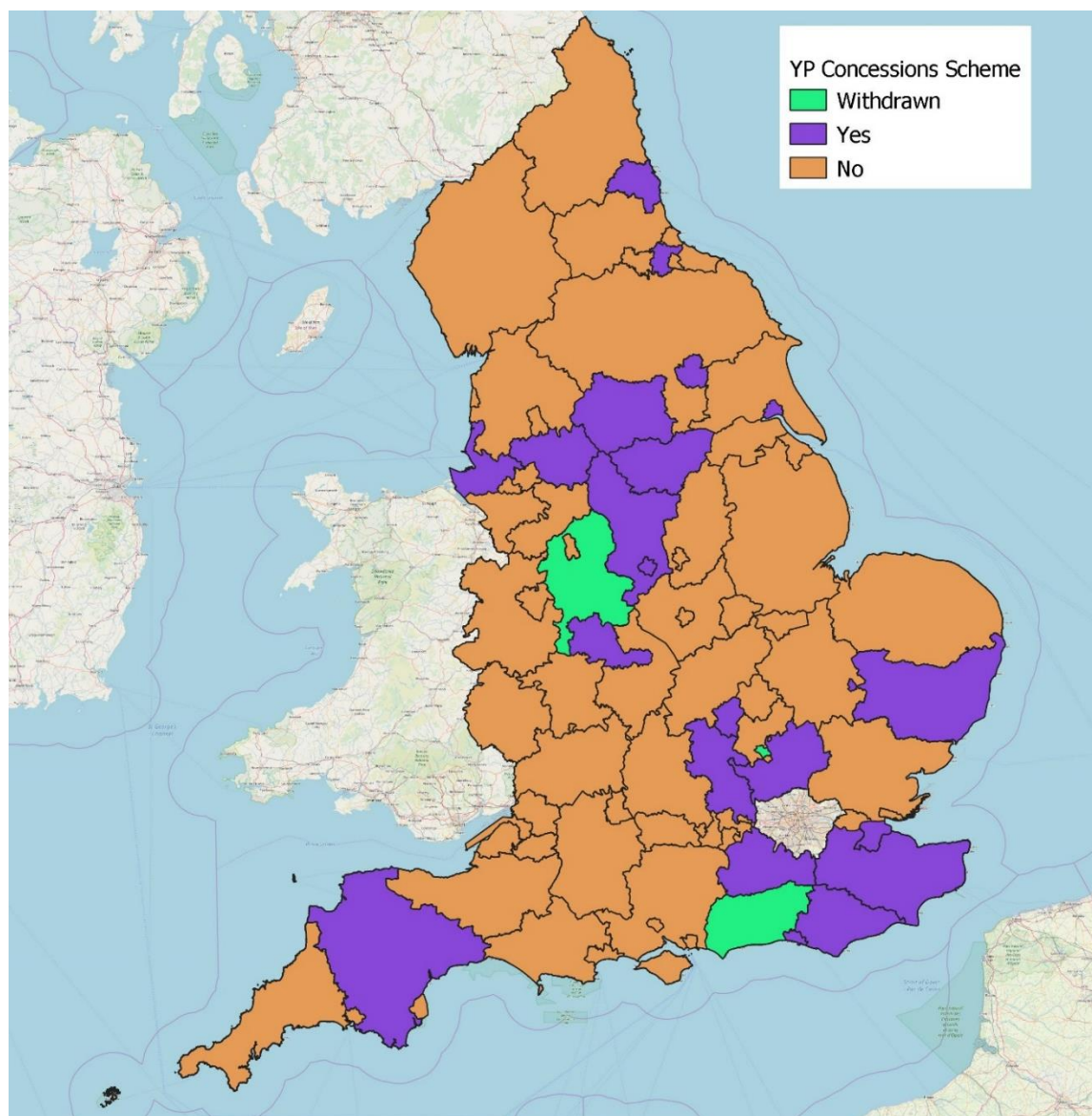

PTEs (Metropolitan Areas)

- 4.2.2 As covered in 4.3.1, the multi-operator products in PTE areas have Young Person and / or Student discounts. On top of this all six PTE areas offer special discount schemes, as outlined in Table 7.

Table 7: PTE Schemes – Young People

LTA	Scheme	Age	Other	Bus	Tram	Rail
Greater Manchester	OurPass*	16-18		Free Travel	50% Discount	
Merseyside	Apprentice Travelcard	19-24	Apprentice	50% Discount		
South Yorkshire	16-18 TravelPass	16-18		£0.80 Single	£0.80 Single	50% Discount
	18-21 Discount Card	18-21		15% Discount	15% Discount	15% Discount
Tyne & Wear	Pop Blue	16-18		Operator discount	£1 Single £2 Day	
West Midlands CA	16-18 Photocard	16-18		Child Fares**	Child Fares	Child Fares
West Yorkshire	16-18 Photocard***	16-18		50% Discount		50% Discount

*Costs £10; **Child cash fares only available to purchase at school times. Season tickets valid at all times; *** Costs £5

Non-PTE

- 4.2.3 Sixteen non-PTE LTAs offer a discretionary concessions scheme to Young People and / or Students. These are outlined in Table 8.
- 4.2.4 An unusual discretionary scheme in relation to perceived fairness is the Stockton on Tees Borough Council 'Pathfinder Fare'. This gives up to 50% discount on Adult bus fares anywhere within the Tees Valley Combined Authority area (Darlington, Hartlepool, Stockton, Middlesbrough and Redcar and Cleveland) but is only available for those who live in Stockton Borough.

Table 8: Non-PTE Schemes – Young People

LTA	Scheme	Age	Other	Bus	Rail	Pass Cost
Brighton & Hove	Sussex Student Card		College Student		34% Discount	n/a
Buckinghamshire	Yoti Citizen Card	16-17		£1.20 & £1.50 Single		£15
Derby City	B-line 2	16-18		25% Discount	25% Discount	n/a
	B-line Apprentice		Apprentice	25% Discount	25% Discount	n/a
Derbyshire	B-line 2	16-18		25% Discount	25% Discount	n/a
	B-line Apprentice		Apprentice	25% Discount	25% Discount	n/a
Devon	Student SmartRider	16-19		£1.30 Single or 33% off		n/a
East Sussex	Freedom Week	16-18		£17 Weekly Ticket		n/a
	Sussex Student Card		College Student		34% Discount	n/a
Hertfordshire	Hertfordshire Saver Card	16-19		50% Discount		£25 p.a.
Kent	16+ Travel Saver	16-19	College Student	Free Travel		£400 p.a.
Kingston-Upon-Hull*	KAT Card	16-18		20% Discount		n/a
Medway	Medway Youth Pass	16-18	College Student	Child Fare before 09:00		£10
Milton Keynes	All-in-1	16-18		£1 Single, £8.50 Week, £27 Month		£5
Stockton-On-Tees	Pathfinder Fare	16-18		50% Discount		£10 p.a.
Suffolk	Endeavour Card	16-19		25% Discount		n/a
Surrey	Student Fare Card	16-18	College Student	50% Discount	33% Discount	£25**
West Sussex	Sussex Student Card		College Student		34% Discount	n/a
York	YoZone Card	16-18		33% or 50% Discount		n/a

*Also valid in parts of East Riding of Yorkshire bordering Hull; **Surrey Student Fare Card is only available for **either** bus or train travel, not both.

4.3 Multi-Operator Tickets

4.3.1 As with the child versions (3.4.1) some (although fewer) multi-operator schemes have Young Person and / or Student discounts. These are shown in Table 9 below.

Table 9: Multi-Operator Schemes – Young People

LTA	Scheme	Eligibility	Price / Discount	Transport Modes	Restrictions?
Bath & North East Somerset	AvonRider Student	Student ID	25%	Bus	n/a
Bournemouth, Christchurch & Poole	Get About Child	16-18 ID Card	40%	Bus	n/a
Bristol, City of	AvonRider Student	Student ID	25%	Bus	n/a
Cornwall	Skipper Child	Under 19	25%	Bus	Plymouth Urban Area
Derby	Spectrum B-Line	16-18 with B-Line card	25%	Bus	05:00 – 23:59
Devon	Skipper Child	Under 19	25%	Bus	Plymouth Urban Area
Greater Manchester	System One YP	16-21	30%	Bus	n/a
	System One Student	16-26 Student ID	25%	Bus	n/a
Hertfordshire	Hemel Hempstead Busnet Child	11 – 19	40%	Bus	Savercard Needed
	St Albans Busnet Child	11 – 19	40%	Bus	Savercard Needed
	Watford Busnet Child	11 – 19	40%	Bus	Savercard Needed
	Welwyn Hatfield Busnet Child	11 – 19	40%	Bus	Savercard Needed
Merseyside	My Ticket	Under 19	£2.20 Day	Bus	n/a
	Young Person Solo	Under 19	50%	Bus	n/a
	Young Person Trio	Under 19	50%	Bus, Rail & Ferry	n/a
	Young Person Saveaway	Under 19	50%	Bus, Rail & Ferry	After 09:30 Weekdays
Norfolk	Young Person Fusion	16-19	15%	Bus	Norwich Urban Area
North Somerset	AvonRider Student	Student ID	25%	Bus	n/a

LTA	Scheme	Eligibility	Price / Discount	Transport Modes	Restrictions?
Nottingham	U19 Robin Hood	Under 19	40%	Bus, Tram & Rail	n/a
	Student Robin Hood	Student in Nottingham	20%	Bus, Tram & Rail	n/a
Nottinghamshire	U19 Robin Hood	Under 19	40%	Bus, Tram & Rail	Nottingham Urban Area
	Student Robin Hood	Student in Nottingham	20%	Bus, Tram & Rail	Nottingham Urban Area
Oxfordshire	18 & Under SmartZone	Under 19	20%	Bus	Oxford Urban Area
Plymouth	Skipper Child	Under 19	25%	Bus	n/a
South Gloucestershire	AvonRider Student	Student ID	25%	Bus	n/a
Staffordshire	Smart Student	College in Stoke	25%	Bus	North Staffordshire
	Smart Uni	University in Stoke	10%	Bus	North Staffordshire
Stoke-on-Trent	Smart Student	College in Stoke	25%	Bus	n/a
	Smart Uni	University in Stoke	10%	Bus	n/a
Swindon	YP TravelPass	Under 20	25%	Bus	n/a
Tyne & Wear	YP Network One	16-18	30%	Bus, Rail, Metro & Ferry	Restricted Rail routes
	Student Network One	Student ID	30%	Bus, Rail, Metro & Ferry	Restricted Rail routes
West Midlands CA	Student Tickets	Student ID	25%	Bus, Tram & Rail	n/a
West Yorkshire	19-25 Card	19-25 or Student ID	33%	Bus & Rail	n/a
Wiltshire	YP TravelPass Plus	Under 20	25%	Bus	Swindon Urban Area

4.4 Commercial Operators

4.4.1 Figure T shows the number of operator Young Person fare schemes by age. As can be seen the under 18 and 16-18 schemes are the most numerous with only a handful of schemes covering those aged over 21.

Figure T: Age Range – Young Person Schemes

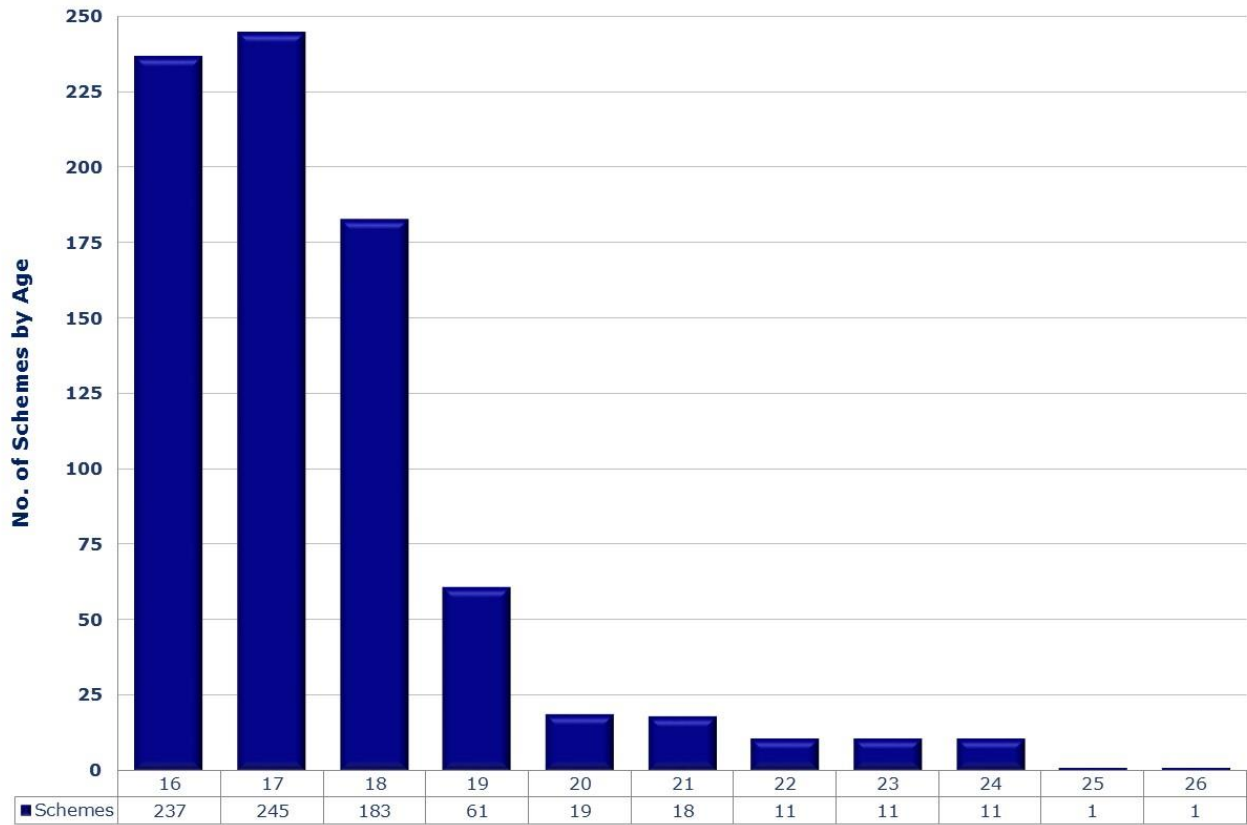

Discount Level

4.4.2 There is no dominant discount level for Young Person schemes, with both 50% or 33% discount accounting for roughly a quarter each of the schemes covered. This is shown in Figure U below, whilst Figure V shows the equivalent for Student fare schemes, where 20%, 25% and 33% are the most numerous of discount levels, but none of them dominant.

Figure U: Discount Level – Young Person Schemes

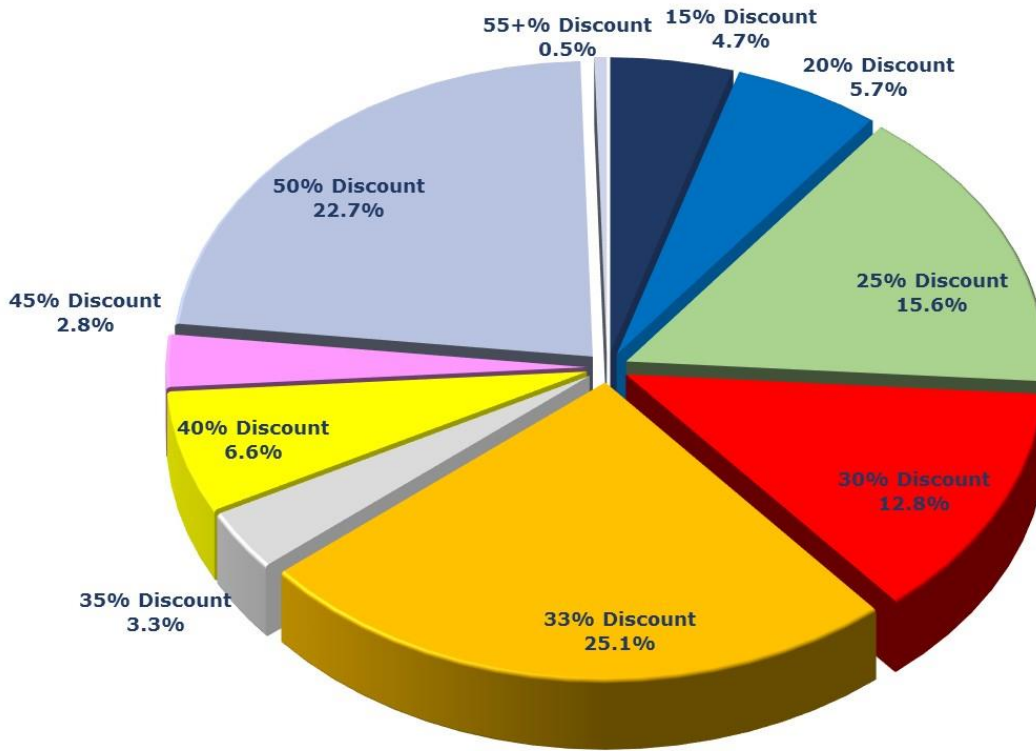
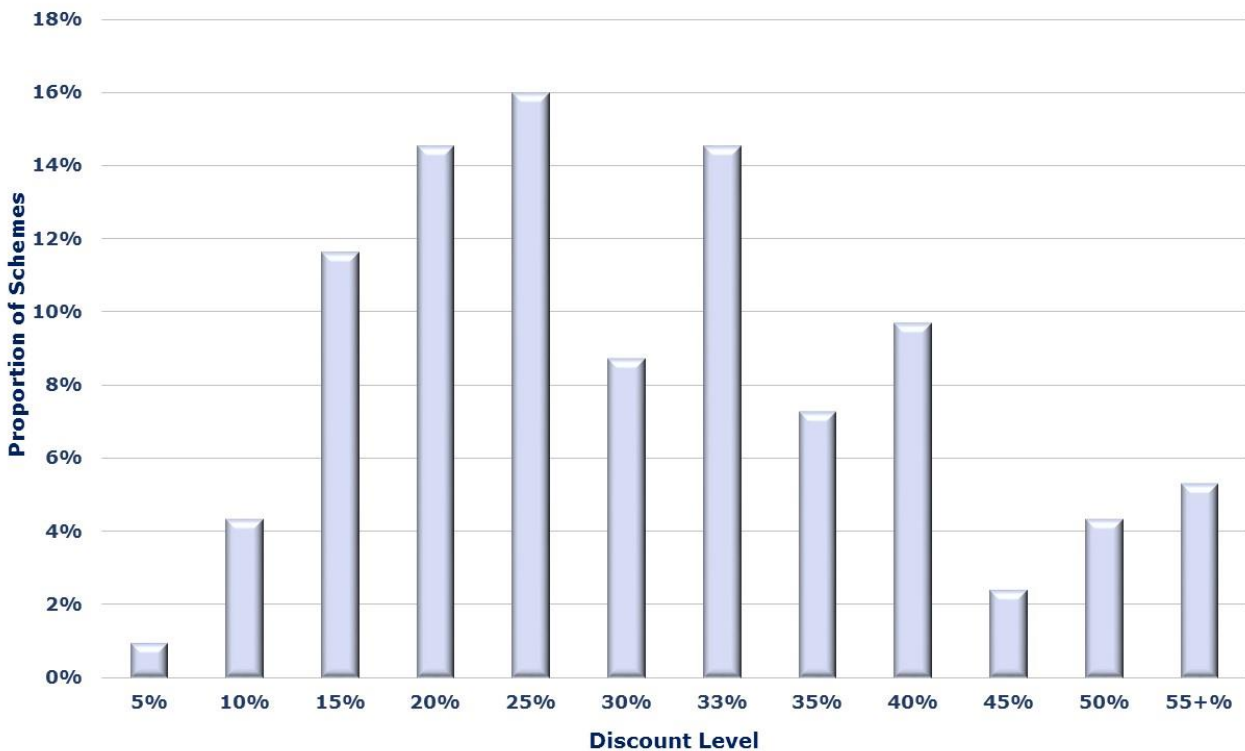

Figure V: Discount Level – Student Schemes



Flat Fare

4.4.3 Figure W shows the distribution of commercial Young Person flat fare schemes. Also discovered were:

- Return Fares:
 - ◆ One each of £2.50, £2.75, £3.00 and £3.50;
- One Day Ticket at £2.70; and
- One Annual Ticket at £750.

Figure W: Distribution of Commercial Flat Fare YP Singles

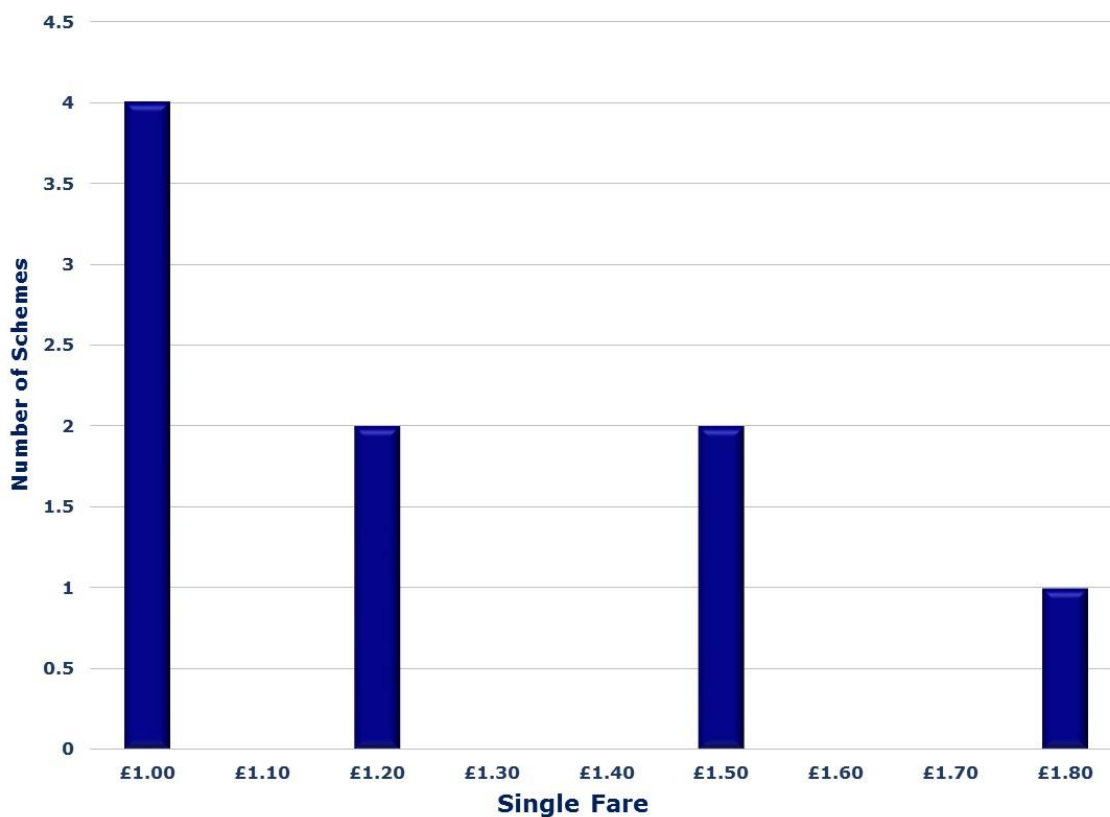

4.4.4 Whilst Term and Academic Year tickets are common for students, the following other schemes are also available with the production of valid Student ID:

- Single Fare:
 - ◆ 1 Free, 1 @ £0.50, 1 @ £1.20 and 2 @ £1.70;
- Return Fare:
 - ◆ One each at £2.20, £3.50, £4.00 and £4.50;
- One Day Ticket at £4.50;

- One Weekly Ticket at £17; and
- 10 Journey tickets:
 - ◆ One each at £15, £20 and £25.

4.5 Proof of Age Requirement

4.5.1 As shown in Figure X, just under half of the discount schemes require proof of age when purchasing the ticket from the driver. A third of schemes involve some kind of ID card when purchasing from the driver whilst the remaining 20% approx. require a form of ID when purchasing off-bus or setting up an account.

Figure X: Proportion of Schemes Requiring Proof of Age – YP

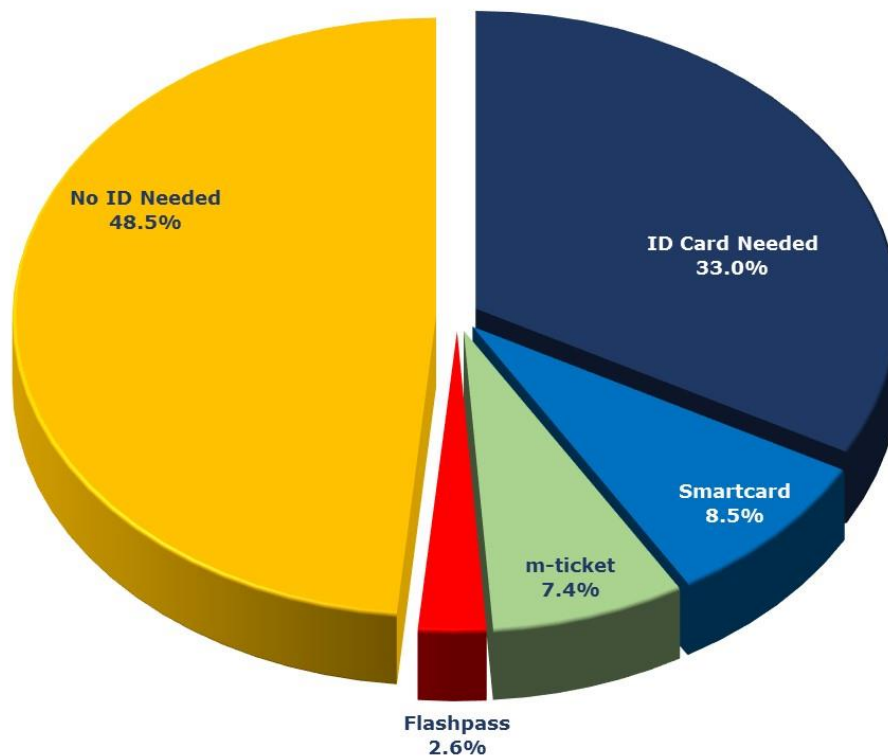

4.6 Scotland and Wales

4.6.1 Although outside of the remit of this work, it is worth a quick note about Scotland and Wales as a comparator against English schemes. In Scotland the transport element of the Young Scot Card is available to all 16-18 year olds plus 19-25 year olds who volunteer full time. Holders receive a third off the price of an adult single on most bus journeys and similar on single and return rail tickets. Young Scot is fully reimbursed by Transport Scotland as part of the Scottish Concessionary fare scheme.

- 4.6.2 For rail travel Young Scot offers a season ticket discount of 50% but the season ticket discount is not available for bus fares. For those who live on a Scottish Island, they are entitled to four free journeys by ferry each year (redeemable via voucher).
- 4.6.3 In Wales the My TravelPass card gives holders around a third off bus travel. This is offered by all Welsh bus operators to 16-18 year olds, whilst 29 operators extend the discount until the holder's 22nd birthday. My TravelPass is reimbursed by the Welsh Government, with a generation factor applied.

5.1 Introduction

5.1.1 For this section the 322 bus-based group discount schemes have been split two ways as shown in Table 10. A group ticket is one that allows more than one person to travel using it, a family ticket is counted as one which requires at least one child to be travelling in the group.

Table 10: Group and Family Schemes

Operator Type	Group Ticket	Family Ticket	Total
Multi-Operator	3	29	32
Single Operator	130	160	290
Total	133	189	322

5.2 Maximum Family Size

5.2.1 As shown in Figure Y, although two adults and three children is the most frequent maximum family size specified, there is a wide array of family make-up permitted by family tickets. Within the maximum size there is flexibility – extra children can be substituted for an adult and so on, but many schemes require that at least one adult and/or at least one child is part of the 'Family'. Some schemes allow a dog to replace a person.

Figure Y: Maximum Family Size by Operator Type

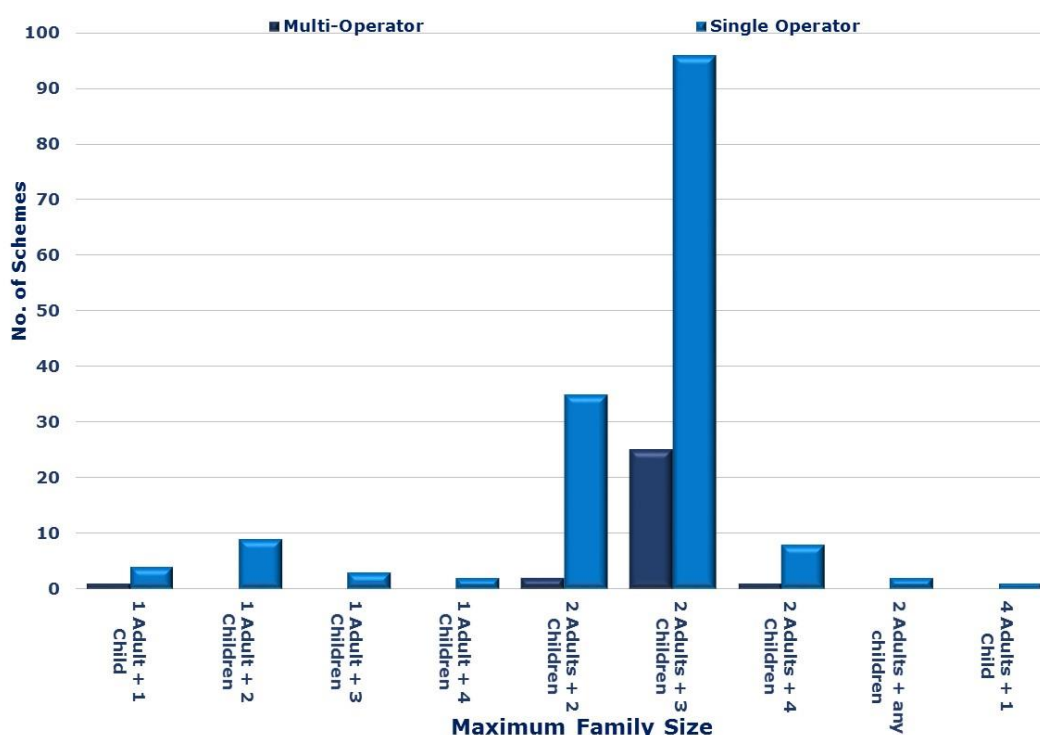

5.3 Maximum Group Size

5.3.1 As with family size, there is a dominant maximum group size but there is still a large variation in specified maximum group sizes. As shown in Figure Z the dominant maximum group size varies between multi-operator (four people) and single operator (five people) tickets. Group (rather than family) versions of multi-operator fares are rare.

Figure Z: Group Size by Operator Type

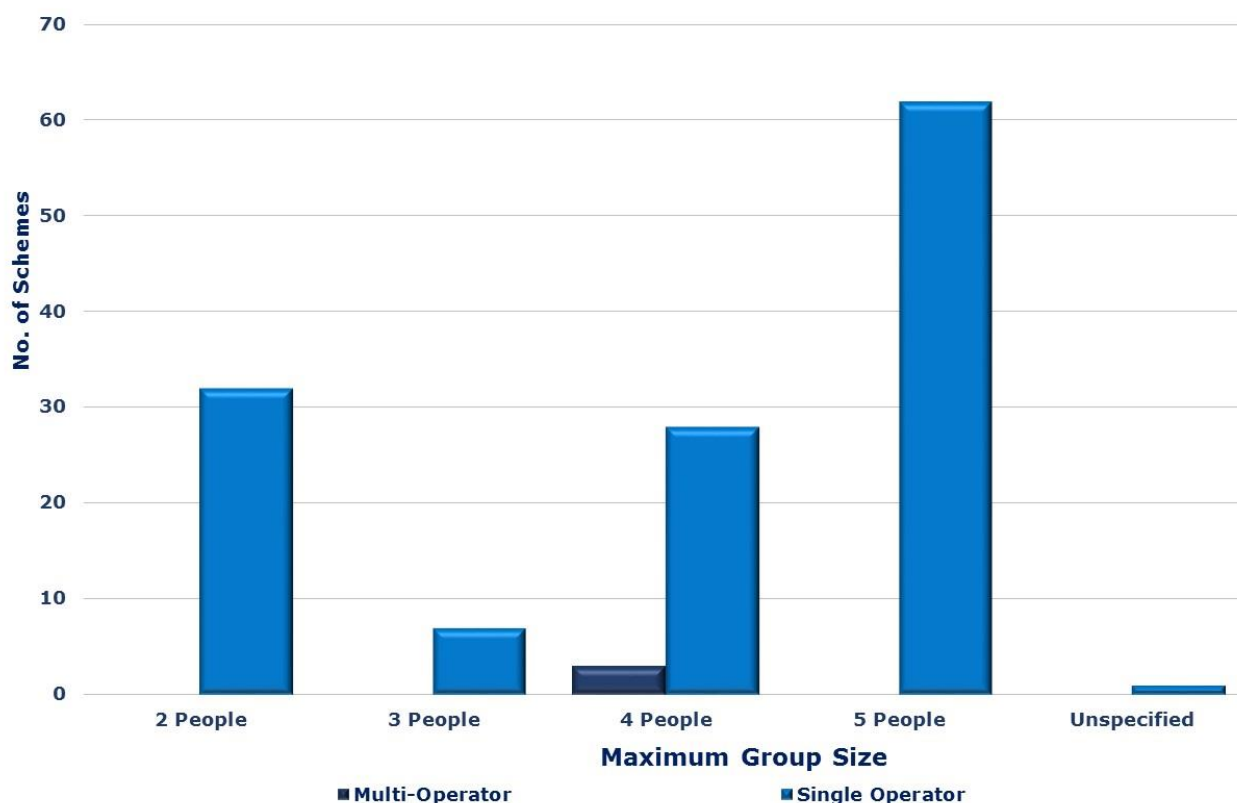

5.4 Discount Level

5.4.1 Figure AA sets out the discount offered by group and family tickets compared to purchasing the equivalent single person products for the maximum number of people permitted by the ticket. As shown, the most common level of saving is between forty and sixty per cent. The tickets at the higher end of the spectrum present good value for money even if the group or family is smaller than the maximum permitted number of people.

5.4.2 Figure BB shows the discount rate by group type. Family tickets are strongest around the 45-60% mark whilst group tickets are quite evenly spread but are stronger at the upper discount levels. This is no doubt helped by the evening and weekend group tickets such as '5 for a Fiver'.

5.4.3 The majority of Family or Group tickets are day tickets. The availability of longer period Family or Group tickets is rare.

Figure AA: Discount Level by Operator Type

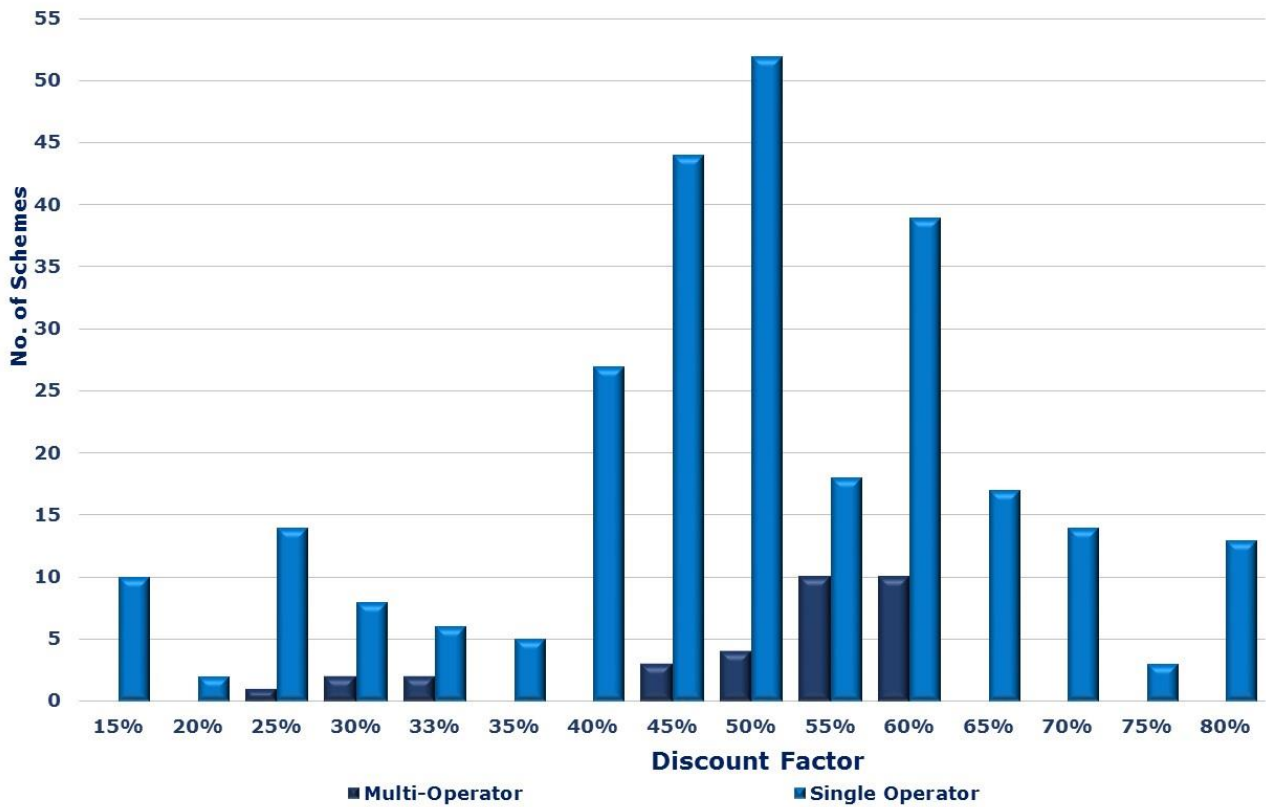
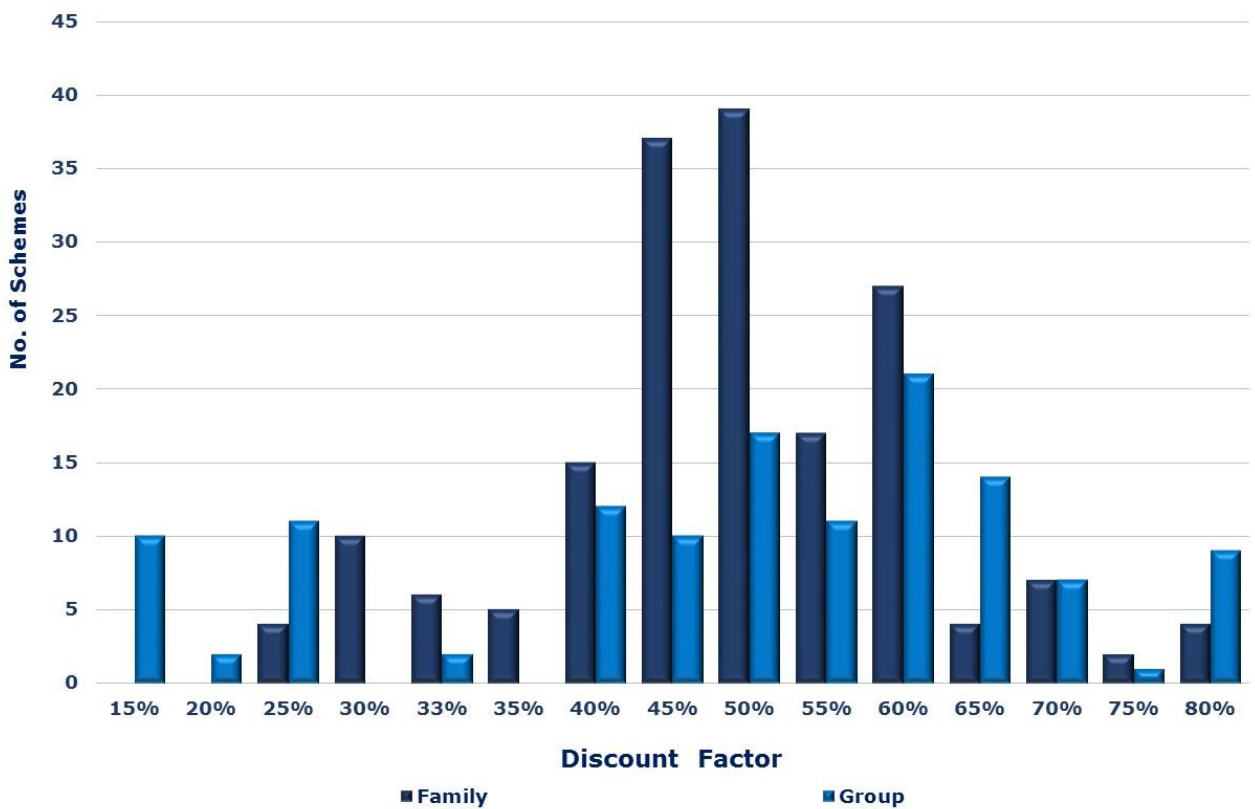

Figure BB: Discount Level by Group Type



Time of Validity

- 5.4.4 Given the level of discount afforded by a group or family ticket, it may be somewhat of a surprise that (as shown in Figure CC) just under 80% of all multi-person tickets are valid all day including weekdays. The majority of the Monday to Friday restricted tickets are valid after 09:30.

Figure CC: Time of Validity for Multi-Person tickets

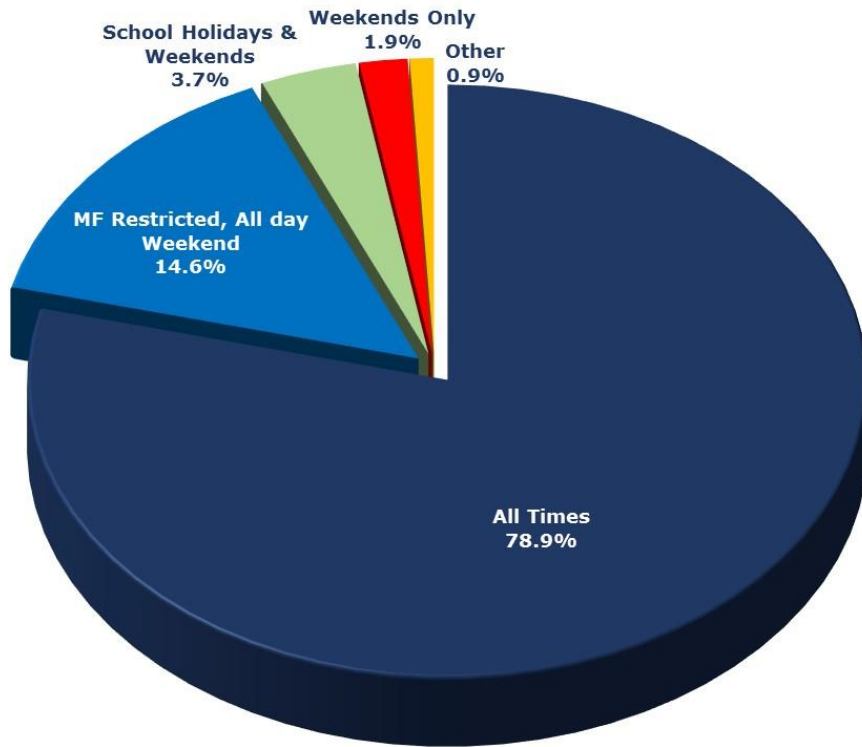

6.1 Introduction

6.1.1 This section covers the following modes of transport:

- a) Coach travel;
- b) National Rail;
- c) Light Rail; and
- d) Domestic ferry services.

6.2 Coach Travel

6.2.1 There are three distinct types of coach operation:

- a) Coaches used on local bus services (such as Stagecoach X5 between Oxford and Cambridge) – already covered in previous chapters;
- b) National coach services; and
- c) Regional coach services.

National Coach Services

6.2.2 There are two major national operators, National Express and Megabus. The discount schemes offered by these operators are shown in Table 11.

Table 11: National Coach Operators

Operator	Scheme	Criteria	Discount	Card Cost
National Express	Child Fares	Aged under 16	50%	n/a
	Young Person’s Coachcard	Aged 16-26	33%	£12.50 p.a.
	Senior Coachcard	Aged 60+	33%	£12.50 p.a.
	Disabled Coachcard	Disabled	33%	£12.50 p.a.
Megabus.com	Student Discount	TOTUM Card	10%	£15

Regional Coach Services

6.2.3 These are medium to long-distance coach services which do not form part of a national network. In England these services are concentrated mainly in the

South East providing links into London and / or London airports. Table 12 shows the discounts available from a number of the larger coach operators.

Table 12: Regional Coach Services

Operator	Scheme	Criteria	Discount	Restrictions
Berry's Superfast (Tiverton – London)	Child Fare	Aged under 16	50%	
	Young Person Fare	Aged 16-21	20%	Discount card required
	Over 60 Fare	Aged 60 and over	20%	
First RailAir (Reading / Guildford – Heathrow)	Reading Child Fare	Aged under 16	55%	n/a
	Guildford Child Fare	Aged under 16	50%	n/a
	Reading Family Fare	Up to 4 People	30% (2 Adults & 2 Children)	n/a
	Guildford Family Fare	Up to 4 People	7% (2 Adults & 2 Children)	n/a
Greenline (Arriva) (London – Luton / Hemel Hempstead)	Child Fare	Aged under 16	Up to 50%	ID required*
	YP Fare	Aged 16-18	Up to 50%	ID required**
	Student Fare	NUS/ISIC Card	30%	Route 757 only
	Senior Discount	Aged over 60***	33%	n/a
	Group Fare	Up to 2 Adults and 2 Children (or 3 children one adult)	25%	Off Peak Returns only
Kings Ferry (Kent – London)	Student Work Experience	Letter confirming work experience	2 Weeks Free Travel	n/a
Oxford Bus (Oxford – London / Heathrow / Gatwick)	X90 Child Fare	Aged under 16	50%	n/a
	Airline Child Fare	Aged under 16	50%	n/a
	X90 Young Person Fare	Aged 16 – 26	15%	n/a
	X90 Student Fare	Oxford Brookes Student	30%	Return Fare only, ID required
	X90 Senior Fare	Aged 60 and over	15%	n/a
	X90 Kids go Free	1 Adult & 2 Children	Children travel free	Oxford – London only
	X90 Hillingdon Group Fare	Up to 3 Adults and 2 Children	30%	Hillingdon – London only
	Airline Group Fare	Up to 4 People	30% (4 Adults)	n/a

Operator	Scheme	Criteria	Discount	Restrictions
Oxford Tube (Stagecoach) (Oxford – London)	Child Fare	Aged under 16	50%	n/a
	Young Person Fare	Aged 16 – 26	15%	ID card required
	Student Fare	University Student	15%	ID card required
	Brookes Return	Oxford Brookes Student	33%	Return Fare only, ID required
	Over 60s Fare	Aged 60 and over	15%	n/a
	Kids go Free	1 Adult & 2 Children	Children travel free	Oxford – London only
	Group Travel	Up to 3 Adults and 2 Children	7% (3 Adults)	Oxford – London only
Red Arrow (Trentbarton) (Derby – Nottingham)	Child Single	Aged 18 and Under	25%	n/a
	Child Mango	Aged 18 and Under with Mango Card	33%	n/a
	Young Explorer	Aged under 10	£1 flat fare	n/a
	Student Mango	Student Mango card	10%	n/a
South West Falcon (Stagecoach) (Plymouth – Bristol)	Discounted Travel	Aged under 25, 60+ or disabled	33%	n/a
	Group Return	Up to 5 People	60%	n/a

* ID required for travel in Hertfordshire aged over 11; ** ID required, discount only available in Hertfordshire; *** Free travel with ENCTS card at statutory times except Hertfordshire residents who get free travel at all times.

6.3 National Rail

6.3.1 As with most bus operators, children aged under five travel free on National Rail. Children aged five to fifteen automatically get 50% discount on adult fares. PTEs also offer discounted rail travel to children and young people as part of their wider transport discount schemes, as noted in 3.3.1 and 4.2.2.

National Railcards

6.3.2 There are nine national or sub-national railcards, being a mixture of statutory and voluntary schemes (equivalent to discretionary bus schemes). These are listed in Table 13.

Table 13: National Railcards

Name	Status	Eligibility	Discount	Restrictions	Annual Price
16-17 Saver	Voluntary	Aged 16-17	50%	n/a	£30
16-25 (or Young Persons')	Statutory	Aged 16-25 and full-time students	33%	£12 min spend Peak	£30
26-30	Voluntary	Aged 26-30	33%	£12 min spend Peak	£30
Disabled Persons'	Statutory	Registered disabled	33%	Not valid for London Peak	£20
Family & Friends	Voluntary	At least 1 child with named adult	33% Adult 60% Child	Off Peak only	£30
HM Forces	Statutory	Member of or related to member of armed forces	33%	£12 min spend Peak	£21
Network	Voluntary	London and South East area Resident	33%	Off Peak only	£30
Senior	Statutory	Aged 60+	33%	Not valid for London Peak	£30
Two Together	Voluntary	Two named adults travelling together	33%	Off Peak only	£30

Regional Railcards

6.3.3 There are four Regional Railcards in England which are available to any local resident. These are listed in Table 14 including the Train Operating Companies (TOC) it is valid on.

Table 14: English Regional Railcards

Name	TOC	Area & Restrictions	Discount	Annual Price
Cotswold Line	Great Western	Oxford – Worcester Line, Off Peak only	34%	£9.95
Dales	Northern	Leeds / Bradford – Carlisle / Lancaster	33% Adult, 81% Child	£10
Devon & Cornwall	Great Western, Cross Country and South Western	Devon and Cornwall, Off Peak only	33% Adult, £1 flat child fare	£12
Esk Valley	Northern	Middlesbrough – Whitby	33% Adult, 81% Child	£10

Student Fares

6.3.4 The 16-17 Saver is a new railcard aimed at extending child fare levels to, amongst others, those attending higher education. It is unclear whether it will partially or fully replace the following existing local student discount cards:

- Thameslink Student Connect = a free discount card offering 34% off travel for 16-18 year olds on Thameslink and Great Northern services;
 - Surrey Student Farecard = as covered in 4.2.3
 - Cambridgeshire Student Connect = free card offering 50% discount on season tickets for 16-18 year olds on routes through and cross-boundary into Cambridgeshire.
- 6.3.5 Southern offers Brighton 'Unizone' and Worthing 'Unizone' discounted season tickets for holders of 16-17 Saver, Young Persons' Railcard or NUS card and Student ID for university or college in Brighton, Worthing or Chichester.
- 6.3.6 The following TOCs provide discounts on single or return tickets for students:
- Cross Country = 10% off Advance fares with TOTEM or NUS card;
 - Gatwick Express = 34% off adult fares with student ID;
 - LNER = 40% off Advance fares outside main holiday periods; and
 - TransPennine Express = 50% off long distance Advance fares with a Young Persons' Railcard.

Group Travel

- 6.3.7 There are three main types of group travel discounts, with participating operators shown in Table 15, these are:
- Duo / Webduo = 25% discount for two adults travelling together;
 - GroupSave = 33% off travel for groups of three to nine adults;
 - Small GroupSave = GroupSave but only 25% discount; and
 - Small Group Day = 50% discount for four adults travelling together plus £1 flat fare for accompanying children.
- 6.3.8 It is not clear what arrangements there are for through trips requiring more than one TOC's services. Note also that there are further discounts for larger groups but these are negotiated with the TOC and are not discussed here.

Table 15: Group Travel by TOC

Travel Type	Duo	GroupSave	Small GroupSave	Small Group Day
TOC	Gatwick Express Greater Anglia Northern	C2C Chiltern Railways Gatwick Express Greater Anglia Great Northern Great Western London Northwestern Southern South Eastern South Western Stansted Express TfL Rail Thameslink West Midlands Rail	LNER Transport for Wales	Chiltern Railways Stansted Express
Restricted TOC		East Midlands		

Rangers and Rovers

- 6.3.9 The TOCs offer a large range of Ranger tickets (for one day) and Rover tickets (for longer periods) offering unlimited rail travel within specified areas. The areas range in size from a single short line to the All-line Railover.
- 6.3.10 Almost all of these offer child versions at 50% of the adult price and the majority also offers railcard discounts of 33%. We have not reproduced the full list of these tickets here. The National Rail website gives fuller details https://www.nationalrail.co.uk/times_fares/rangers_and_rovers.aspx.

6.4 Light Rail

- 6.4.1 There are currently six light rail systems in England outside London, listed in Table 16 along with the principal LTA and other LTAs within which sections of the system operate.

Table 16: English Light Rail Systems Outside of Greater London

System	Principal LTA	Other LTAs
Blackpool Tramway	Blackpool	Lancashire
Manchester Metrolink	Greater Manchester	-
Midland Metro	West Midlands CA	-
Nottingham Express Transit	City of Nottingham	Nottinghamshire
Sheffield Supertram	South Yorkshire	-
Tyne & Wear Metro	Tyne and Wear	

Children and Young People

- 6.4.2 Manchester Metrolink, Midland Metro, Sheffield Supertram and Tyne & Wear Metro all have special discounts for Children and Young People who are residents of the LTA area. These are covered in 3.3 and 4.2. Figure DD shows the 'walk on' discount fare level available to children and young people – Manchester Metrolink requires proof of age for 11 to 15 year olds but this does not need to be a TfGM Igo card. Children aged over 11 on Sheffield Supertram are required to have a South Yorkshire Megatravel Pass, which entitles the holder to travel for £0.80.

Figure DD: Discount Rate for All Children & Young People by System

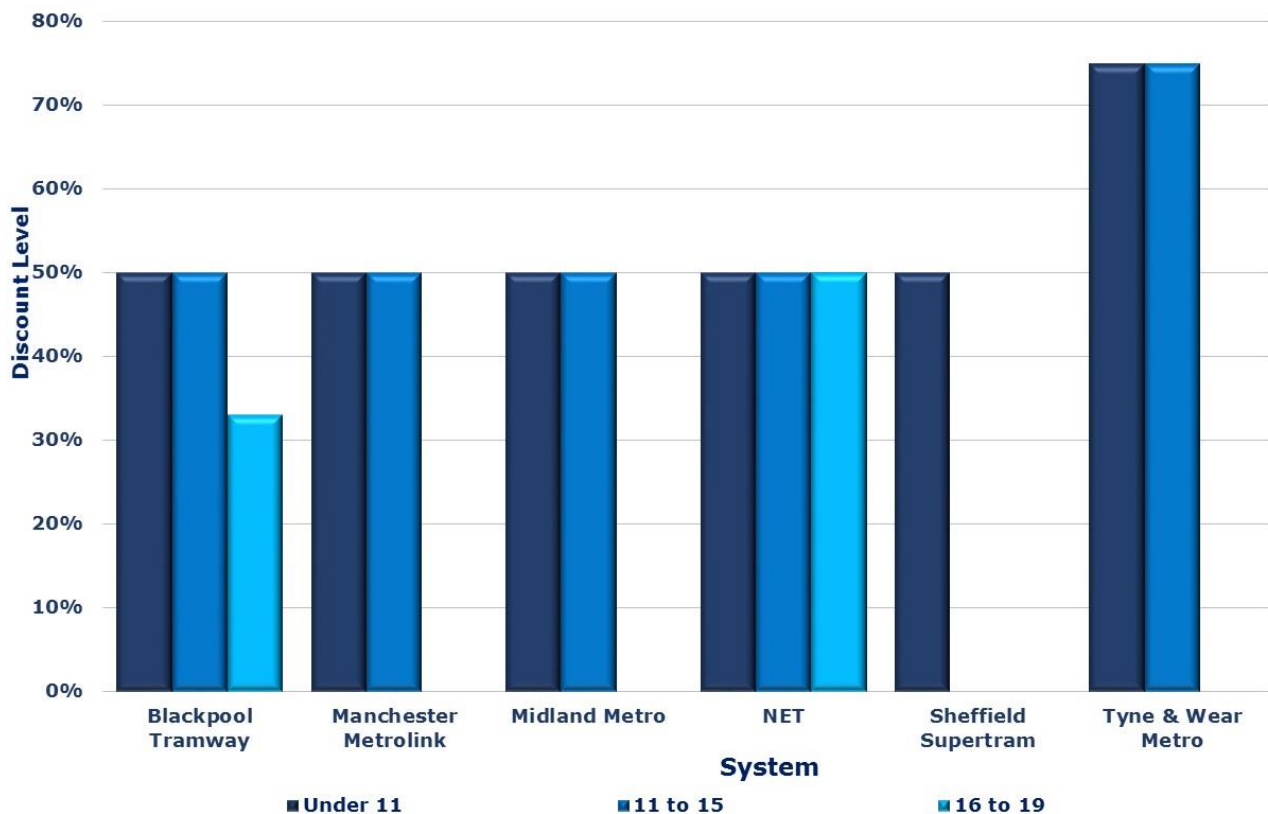

Family and Group Tickets

- 6.4.3 All light rail systems have a family ticket available, with all but Midland Metro's being valid for up to two adults and three children – the latter being up to two adults and four children. Only Blackpool and Midland Metro offer a group ticket, these are valid for up to three people and five people respectively.
- 6.4.4 Figure EE compares the discount available for buying a family and group ticket compared to individual tickets for the maximum number of people. As can be seen there is a wide range of discounts. The Manchester Metrolink family ticket is restricted on weekday, being valid only after 09:30.

Figure EE: Discount Rate for Families and Groups by System

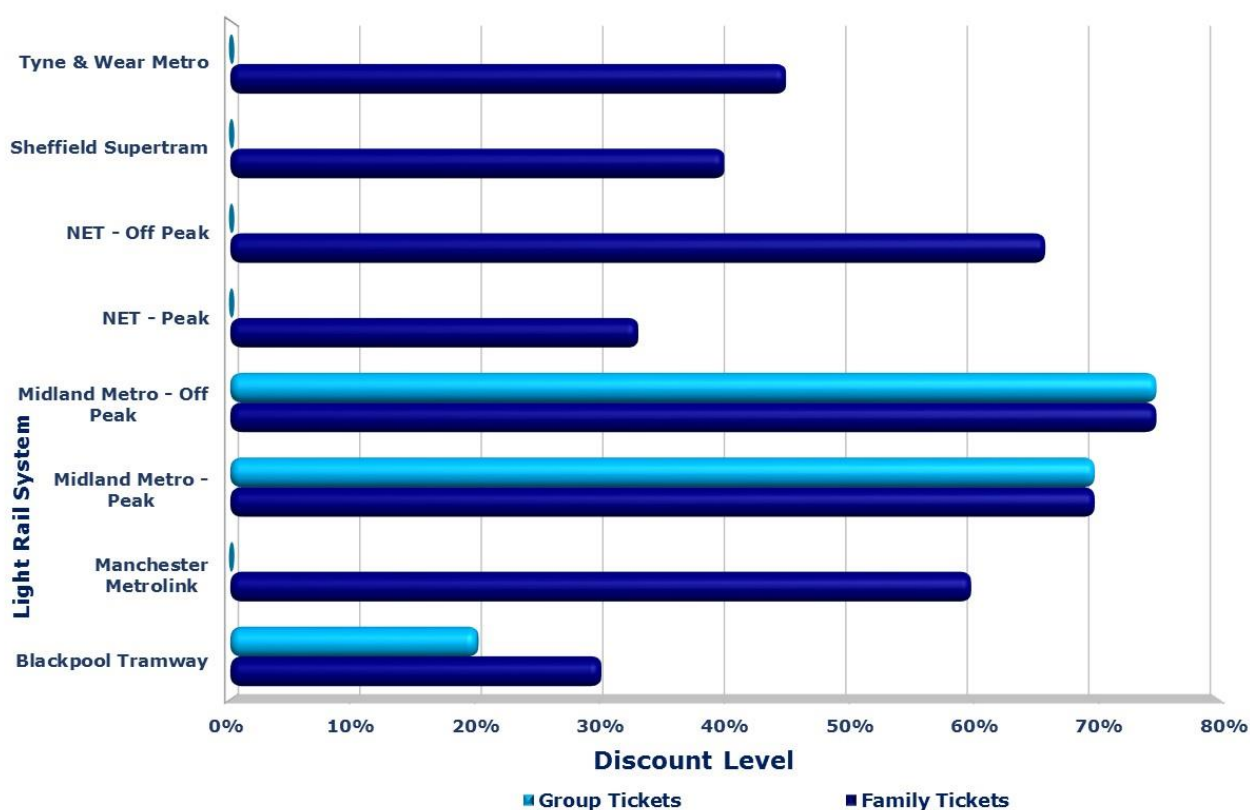

6.5 Ferries – Isle of Wight

6.5.1 Ferry services between mainland England and the Isle of Wight closely resemble international ferry services rather than other domestic ferries. There are two main operators, Red Funnel and Wightlink, both of whom offer some discounts only available to Isle of Wight (IoW) residents.

Children and Young People

6.5.2 Both operators offer free travel to under 5s and up to 50% discount for 5 to 15 year olds. Young People see a variation with:

- Wightlink – 15% discount for Students aged 16 and over with a valid education ID (institution ID, NUS or ISIC card);
- Red Funnel – 30% discount on certain adult fares for 16-19 year olds starting their journey on IoW.

ENCTS Equivalent

6.5.3 Both operators provide discounted fares for those aged 60 and over, Red Funnel at 30% and Wightlink at 25%. Wightlink also offers a discount of 25% for disabled ENCTS pass or Disabled Persons' Railcard holders.

Families and Groups

6.5.4 Both ferry operators provide discounts for large groups such as sports teams which is beyond the scope of this report. Wightlink is the simpler, offering a family ticket for either one adult and four children or two adults and three children, which provides a discount of around 25%. Red Funnel is more complicated, offering:

- Family Day Return – up to four people with at least one adult and one child, discount of up to 50%;
- Super Off-Peak Returns – 40% discount for two adults or two children travelling together, 10% discount for two over 60s travelling together;
- Group Fare – 25% discount per person on groups of four and over.

Other Discounts

6.5.5 Both operators offer a special fare for an IoW resident attending an NHS appointment on the mainland with one other adult (or two if the patient is a child). Wightlink offers a 50% discount whilst Red Funnel offers £10.30 per person, which is the same as a Super Off-Peak Return but with a longer period of validity.

- Red Funnel offers a £10 return fare valid at any time for Job Seekers, this has to be obtained through the Jobcentre Plus in either Newport (IoW) or Ryde.
- Wightlink offers a Discount Fare Scheme for IoW residents who are members of a 'low income household'. The discount level is not specified.

6.6 Ferries – Other

6.6.1 Not all ferry routes provide a discount fare scheme for foot passengers, but we have identified 27 operators which do. Some of these operators cover more than one ferry route. Two of the operators are PTEs, Tyne & Wear and Merseyside and thus ferry travel is included in their multi-modal ticket arrangements.

Child Fares

6.6.2 Only 19 ferry operators offer free travel for children, Figure FF shows the proportion of schemes by age range. Figure GG shows the number of discounted fare schemes by age. Both these show that, unlike bus and rail services, there is no standard lower age for starting to charge a fare or indeed compulsion to allow any age group to travel free. Figure HH shows the discount level applied; whilst half fare is the most common discount, it is no way the majority as it represents less than a third of schemes.

6.6.3 The Shields Ferry (Tyne and Wear) is the only ferry to offer a Young Person discount. This is offers a 40% discount on single and 30% discount on day tickets to holders of 'Pop Blue' cards (see 4.2.2). Three operators offer Student discounts of 10%, 15% and 20% respectively.

Figure FF: Proportion of Ferry Child Free Travel Schemes by Age Range

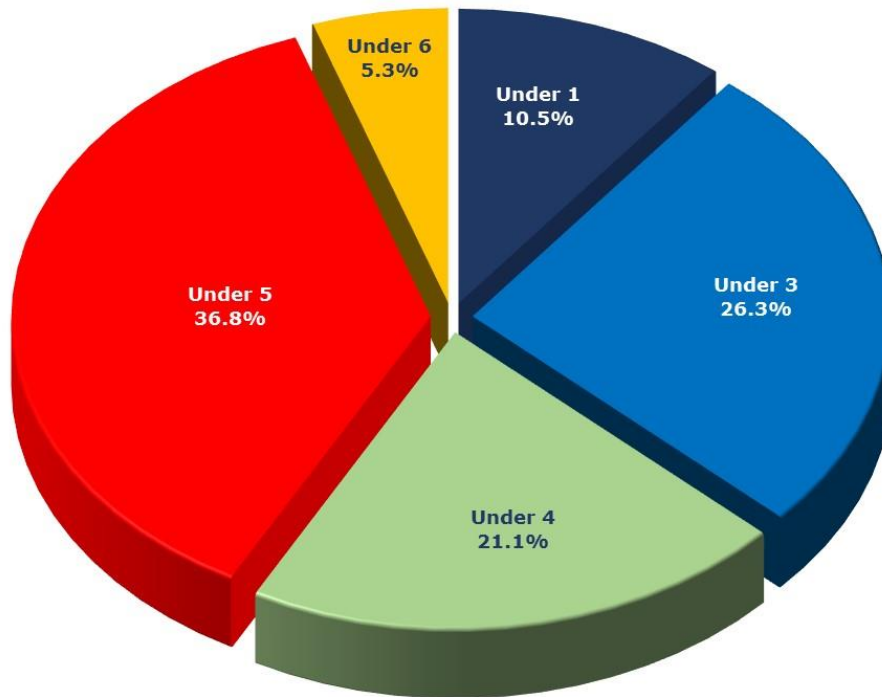

Figure GG: Ferry Child Discount Travel Schemes by Age (Excluding Free Travel)

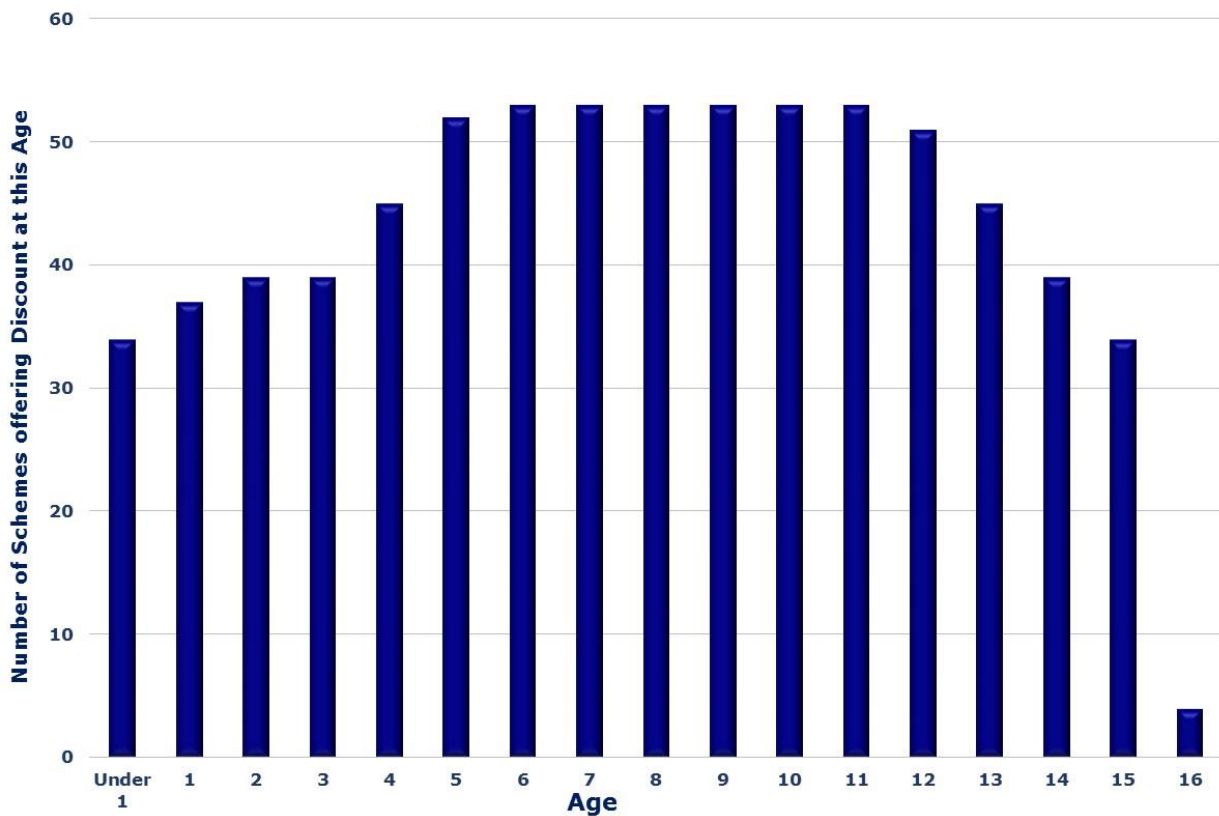
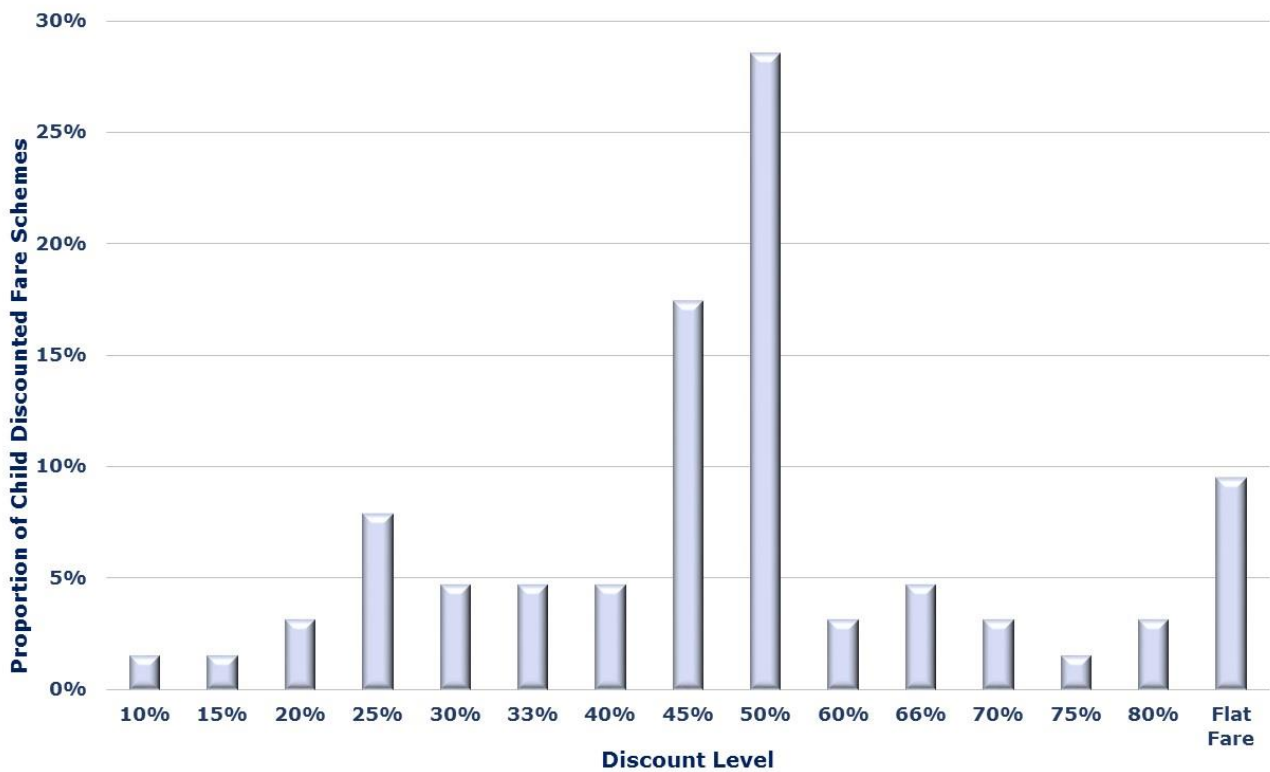

Figure HH: Ferry Child Discount Travel Schemes by Discount Level



ENCTS and Older Person's Discounts

- 6.6.4 There are three operators who offer some level of concession to ENCTS holders:
- Mersey Ferries = free travel for Merseyside ENCTS holders on cross-river travel;
 - Nexus = Free travel for Nexus Gold Card holders (for which an annual charge is made), 60p off-peak flat fare for all other ENCTS card holders; and
 - Tilbury to Gravesend Ferry = Free travel all day for Kent, Medway and Thurrock ENCTS card holders; free off-peak travel for all other ENCTS card holders.
- 6.6.5 Five other operators offer discounts to ENCTS card holders or passengers aged 65 and over. There is no consistent discount, it ranges between 5% and 45%.

Families

- 6.6.6 Eight operators provide a discount ticket for families travelling together, all but two for a maximum of two adults and three children – the remaining two are for two adults and two children. Figure II shows the breakdown of discount offered compared to buying individual tickets for all family members, with 30% being the most popular.

Other

- 6.6.7 The Gosport to Portsmouth Ferry offers a 10% discount to members of the Armed Forces.

Figure II: Ferry Family Discount Schemes by Discount Level

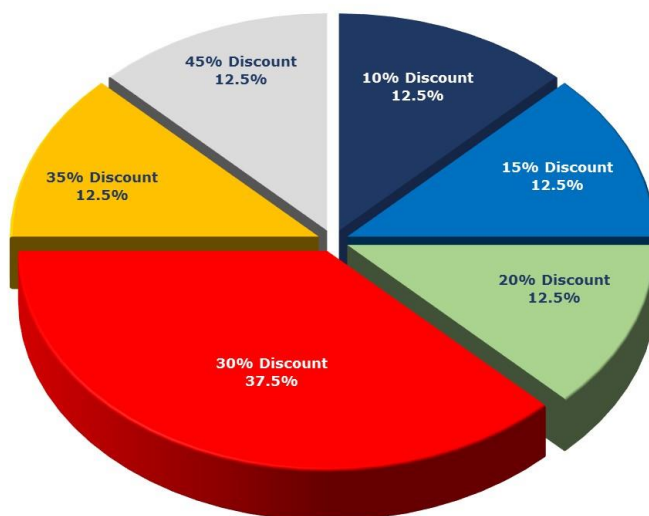

Appendix A: Concessionary Fare Legislation

1. Introduction

- 5.14 These Notes are taken principally from Chapters 1 and 2 of House of Commons Briefing Paper SN01499 (July 2015)
<http://researchbriefings.files.parliament.uk/documents/SN01499/SN01499.pdf>

2. England (Statutory) Concessionary Fare Schemes

How was the scheme developed?

- 2.1 The Labour Government first introduced a local, half-fare statutory scheme in 2001. The concession was gradually extended over the following seven years. The concession initially applied to women over the age of 60 and men over 65, but this had to be altered following a legal judgement that found it discriminatory. The eligible age was subsequently lowered to 60 for all, but has been increasing since April 2010 when the female state pension age began to rise.
- 2.2 The Labour Government announced in its July 1998 transport White Paper that it intended to introduce "a national minimum standard for local authority concessionary fares schemes for elderly people with a maximum £5 a year charge for a pass entitling the holder to travel at half fare on buses".
- 2.3 This was legislated for by sections 145 to 159 of the Transport Act 2000, which gave 'elderly people' (defined at the time as "a person who has attained pensionable age") and specified disabled people the entitlement to a half-fare concession on local bus travel during the 'relevant time' (i.e. Saturdays, Sundays and Bank Holidays and between 0930 and 2300). Local authorities would issue a permit, provided free of charge, to those 'residing' within the authority boundary allowing them to claim the concessionary fare. Following consultation, the scheme came into effect on 1 June 2001 (1 April 2001 within London).
- 2.4 In February 2001 the Government announced that it would introduce legislation to amend the law so that men would qualify for travel concessions at the same age as women.³ This followed a case brought before the European Court of Human Rights (ECHR), contending that the statutory concession constituted sex discrimination because women became eligible for it at aged 60 while men had to wait until 65.
- 2.5 The Travel Concessions (Eligibility) Act 2002 amended the legislation so that, from 1 April 2003, the definition of 'elderly people' for the purposes of the concession became "persons who have attained the age of 60". It also included a power for the Secretary of State to make an Order to replace references to age 60 with a formula that would increase the eligible age alongside changes to pension age.

DETR, New Deal for Transport: Better for everyone, Cm 3950, July 1998, para 4.81 2 *DETR, Implementation of statutory minimum concessionary fares commitment, 20 December 1999; and Transport Act 2000 (Commencement No. 1 and Transitional Provisions) Order 2000 (SI 2000/3229)* 3 *DETR press notice, "One million set to benefit from equal travel concessions", 19 February 2001*

3. Concessionary Bus Fares

- 3.1 The concession was extended from a half-fare concession on local bus services to free travel on local services throughout England from 1 April 2006.⁶ The Government provided an extra £350 million for 2006-07 through the Formula Grant system to fund the cost to local authorities.
- 3.2 The Government extended the concession to provide free local bus travel England-wide from 1 April 2008 via the Concessionary Bus Travel Act 2007. The Act includes a power to allow, in the future, for mutual recognition of national concessionary bus passes across the United Kingdom so it has the potential to be a national UK-wide scheme.
- 3.3 In the December 2009 Pre Budget Report the Labour Government stated that the qualifying age for the statutory concession in England would rise to 65 between 2010 and 2020, in line with the planned rise in the female pension age. The Travel Concessions (Eligibility) (England) Order 2010 (SI 2010/459) legislated for this change from 6 April 2010.
- 3.4 Due to further changes to the state pension age by the Coalition Government, the age of eligibility for the statutory concession will rise faster and higher than originally envisaged – to 66 by October 2020 (and presumably in line with subsequent rises after that).

4. What are the Current Arrangements?

- 4.1 Under the provisions of the Transport Act 2000, as amended, in England outside London the statutory concession currently consists of guaranteed free off-peak travel for older and disabled people on all local buses anywhere in England from 0930 until 2300 on weekdays and all day at weekends and on Bank Holidays.
- 4.2 'Eligible services' are as specified in the Travel Concessions (Eligible Services) Order 2002 (SI 2002/1016), as amended, made under section 146 of the 2000 Act. Broadly. This defines eligible services as 'local services', which are buses carrying passengers at separate fares locally, other than on private trips.
- 4.3 It was estimated that the Act benefited approximately one million men, see: DTLR press notice, "One million extra men to get cheaper fares", 27 February 2002; the background to the Act is given in HC Library briefing paper RP 01/80 6 Travel Concessions (Extension of Entitlement) (England) Order 2005

(SI 2005/3224) 7 HC Deb 27 February 2006, c328W; this funding was distributed to local authorities according to the overall local government grant formula and was not ring-fenced⁸ for more information on the Act, see HC Library briefing papers RP 07/19 and RP 07/53;

- 4.4 The format for the new national concessionary pass was unveiled in September 2007 and in mid-2007 the DfT published a study on the impact of the all-England concession on bus company practices, see: *Steer Davies Gleave for the DfT, Impact of concessionary fares, April 2007* 10 DfT, *Statement on Changes to Concessionary Travel announced in Pre-Budget Report, 9 December 2009*; and: *Guidance for Local Authorities on the change in the age of eligibility for Concessionary Travel, March 2010* 11 see also section 2 of the Transport Act 1985, as amended.
- 4.5 This was most recently amended in 2009. Following consultation, the definition of 'eligible services' was revised to exclude services on which the majority of seats can be reserved in advance of travel; that do not run for a period of at least six consecutive weeks; that are operated primarily for their historical interest or for tourism; rail replacement services; and services where the fare charged by the operator has a special amenity element. If they wish, local authorities can still fund these services as part of their discretionary schemes (see section 2, below).

DfT, Consultation on the definition of eligible services for the statutory bus concession in England, October 2008; and: *Government response to consultation on clarifying the definition of which services are eligible for the statutory bus concession in England, March 2009*

- 4.6 Initially, the scheme had to be reviewed every five years but was revised in April 2018 to remove the cessation date previously set at May 2018.

DfT, The Mandatory Travel Concession (England) (Amendment) Regulations 2018.

5. Eligibility - Disabled People

- 5.1 Eligible disabled people are those specified in section 146 of the 2000 Act, as amended: "disabled person" means a person who:

(a) is blind or partially sighted,

(b) is profoundly or severely deaf,

(c) is without speech,

(d) has a disability, or has suffered an injury, which has a substantial and long-term adverse effect on his ability to walk,

(e) does not have arms or has long-term loss of the use of both arms,

(f) has a learning disability, that is, a state of arrested or incomplete development of mind which includes significant impairment of intelligence and social functioning, or

(g) would, if he applied for the grant of a licence to drive a motor vehicle under Part III of the Road Traffic Act 1988, have his application refused pursuant to section 92 of that Act (physical fitness) otherwise than on the ground of persistent misuse of drugs or alcohol,

5.2 Certain people are automatically passported to free bus travel:

- People in receipt of the higher rate DLA mobility component;
- People receiving PIP who have been awarded at least 8 points against either the PIP "Moving around" and/or "Communicating verbally" activities;
- Recipients of the War Pensioner's Mobility Supplement; and
- People registered with a local authority as blind, partially-sighted, or profoundly or severely deaf

5.3 This was defined in the Travel Concessions (Eligible Services) (Amendment) Order 2009 (SI 2009/575). The Department recommends that, where there is doubt about eligibility, local authorities seek independent medical evidence. It is for a local authority to determine whether someone is a 'disabled person' or not based on the definitions above and on the guidance issued by the Department for Transport, to which they must have regard when assessing eligibility. The guidance is:

DfT, Guidance to local authorities on assessing eligibility of disabled people in England for concessionary bus travel, Version 1.2, April 2013.

6. Eligibility - Older People

6.1 Eligible older people are those specified in Regulation 2 of the 2010 Regulations as being "in the case of a woman, her pensionable age [and] in the case of a man, the pensionable age of a woman born on the same day". Due to the policies of successive governments to raise the female state pension age and equalise it with that of men, this means that the eligible age for the statutory concession is also increasing.

6.2 In 1995 the Conservative Government legislated to increase the female state pension age from 60 to 65 between 2010 and 2020. As indicated above, in February 2010 the Labour Government legislated to increase the eligibility for the statutory concession in line with this rise in the pension age.

6.3 However, due to planned changes to the state pension age made by the Coalition Government between 2010 and 2015, the age of eligibility for the

statutory concession will rise faster and higher than originally envisaged – to 66 by October 2020.

Full details of the plans to equalise and then increase the state pension age are included in HC Library briefing paper SN6546

7. Scheme Administration

7.1 The scheme is administered by 'travel concession authorities' (TCAs). In England these are county, unitary and metropolitan authorities and the 33 London councils.

7.2 These authorities were made TCAs in 2011 following changes made by the Labour Government prior to the 2010 General Election. This removed the responsibility for administering concessionary fare schemes from non-metropolitan district councils. The Government argued that making only upper tier authorities TCAs would:

- deliver efficiencies;
- make the funding formula easier;
- enable discretionary concessions to be maintained at a local level;
- harmonise concessionary travel responsibilities with wider transport authority ones; and
- assist with the roll-out of smart ticketing

ibid., pp12-13 16 the State Pension Age Calculator can be used to work out the date and age at which one becomes eligible for the concession.

Section 126 and Schedule 4 of the Pensions Act 1995 18 guidance for the new travel concession authorities was published in December 2010, see: DfT, Guidance for Travel Concession Authorities on the England National Concessionary Travel Scheme, December 2010.

Concessionary Bus Travel Act 2007 (Variation of Reimbursement and Other Administrative Arrangements) Order 2010 (SI 2010/1179); the Order was debated in both Houses, see: DL (4) Deb 16 March 2010; and: HL Deb 15 March 2010, cc183-190GC

Information on the funding of bus services in general, rather than concessionary fares, can be found in HC Library briefing paper SN1522.

8. How are Concessions Funded?

8.1 It costs approximately £1.3 billion per annum to provide the statutory free local bus travel concession in England. This is a significant increase since the concession was introduced. Over the years there has been a lot of debate

about the adequacy of the funding for first the discretionary and then, after 2001, the statutory, bus concession schemes. This became particularly acute after changes in 2009 to the mechanism for calculating the allocations to local authorities.

- 8.2 The most recent change followed the decision to wrap up funding for the statutory concessionary bus pass with the Formula Grant from April 2011. Towards the end of 2010 the Department for Communities and Local Government (CLG) consulted on how the transfer of responsibility for concessionary travel (from lower tier to upper tier authorities – see above) would be taken into account in authorities' funding allocations from 2011/12.
- 8.3 Between 2008 and 2011 the Department for Transport provided a special grant, totalling just over £650 million, to local authorities to pay for the statutory concession. However, the majority of funding was provided by CLG through Formula Grant. Since 1 April 2011, all funding has been through the Formula Grant.

9. Is it Going to be Means-tested?

- 9.1 The bus pass is phenomenally popular amongst older and disabled people: as of 2014 approximately four fifths of those eligible for the bus pass take it up; in London take up is essentially universal. It is clear that those in receipt of the bus pass highly value the freedom and independence it gives them. It is also worth noting that across the English local bus network more than one in five journeys is made using a concessionary pass. It is not clear whether some of these services could survive without this cohort of passengers.

DfT, Consultation Response Document: Consultation on possible changes to the administration of concessionary travel, December 2009, paras 12&18 21

DfT, Concessionary travel (BUS0811), 16 December 2014 22 ibid.,

Concessionary travel data (BUS0811 and 0820),

DfT, Local Authority special grant funding in 2010/11 for the national bus concession in England: Consultation Paper, November 2009 25 CLG, Revenue Support Grant for 2011-12 and 2012-13 and related matters:

Consultation paper, December 2010, paras 26-27 26 HC Deb 11 October 2010, c47W; DfT, Special Grant Report (No. 129), HC 256, 19 February 2008; and: DfT, Special Grant Report (No. 130), HC 306, 28 January 2010 27 op cit., Concessionary travel (BUS0820)

- 9.2 There are those who argue that the universal bus pass is simply not financially viable; that the universality of the bus pass is a waste of resources and that the significant amount of money put aside for bus passes could be better spent if older recipients were means tested. The money saved from not providing the bus pass to those with means to purchase their own bus tickets

could be spent on other things, for example a new concession for younger people in higher education or those actively looking for work.

- 9.3 All major parties committed to protecting the free bus pass for older people in their 2015 manifestos. However, supporters of all three main parties in England recommended that they look at means testing so-called 'middle class benefits' such as the statutory bus concession after the election.

10. Discretionary Concessionary Schemes in England

- 10.1 Local authorities have discretion over any concessionary fares that they choose to offer in addition to the statutory concession. Any such discretionary concessions are funded from general spending.

- 10.2 Section 93(7) of the Transport Act 1985, as amended, allows integrated transport authorities (ITAs) and local authorities in England, Scotland and Wales (outside London) to provide, at their discretion, travel for specified groups of people. In England, they are:

- persons whose age does not exceed sixteen years;
- persons whose age exceeds sixteen years but does not exceed eighteen years and who are undergoing full-time education;
- persons who are blind or partially sighted;
- persons who are deaf;
- persons who are without speech;
- persons who have a disability, or have suffered an injury, which has a substantial and long-term adverse effect on their ability to walk;
- persons who do not have arms or have long-term loss of the use of both arms;
- persons who have a learning disability, that is, a state of arrested or incomplete development of mind which includes significant impairment of intelligence and social functioning;
- persons who, if they applied for the grant of a licence to drive a motor vehicle would have their applications refused on grounds of physical fitness (otherwise than on the ground of persistent misuse of drugs or alcohol);
- any person travelling as the companion of an eligible disabled person and who requires the assistance of a companion in order to travel on journeys on public passenger transport services; and
- any other classes of persons as the Secretary of State may by order specify.

- 10.3 They may also provide a discretionary concession to anyone over the female state pension age (i.e. in the case of a woman, someone who has attained her pensionable age, and in the case of a man, someone who has attained the pensionable age of a woman born on the same day).
- 10.4 This, in effect, forbids local authorities from offering discretionary concessions to the over 60s under the powers in the 1985 Act. However, they can offer such a concession under their 'well-being' powers in Part 1 of the Local Government Act 2000, as amended. Government guidance states:
- 10.5 Whilst local authorities are no longer able to use their powers under the Transport Act 1985 and the Greater London Authority Act 1999 to provide travel concessions to those below the pensionable age applying to women, subject to their own legal advice, they might be able to use their well-being powers under the Local Government Act 2000 to provide discretionary travel schemes to such people.
- 10.6 However, English National Concessionary Travel Scheme (ENCTS) passes may not be issued to these people and the arrangements with transport operators would have different legal arrangements. We advise any local authority seeking to offer such concessions to seek advice from their own lawyers before they are established.
- 10.7 ITAs replaced passenger transport authorities (PTAs) in the metropolitan areas of England from 9 February 2009 under section 77 of the Local Transport Act 2008; for more information see section 3 of HC Library briefing paper SN4351.
- 10.8 Note that 'eligible services' only comprises registered local bus services and any LTA concessionary scheme including extension of use to other modes or groups of services falls under the discretionary legislation.

11. Commercial Fare Reductions

- 11.1 Section 6 of the Transport Act 1985, which replaced the old system of Road Service Licences with Registered Local Bus Services, included no provision for fare detail within service registrations. Any operator is free to charge whatever fare it sees fit for any passenger or group of passengers, provided that the fares charged are set independently by each operator.
- 11.2 Removal of the need to apply to the Traffic Commissioner to make any change to fares made the introduction of day and period tickets far easier and for these to cover local and travel to work areas rather than local authority boundaries. In the years following the Act, such tickets have become the norm in many areas and form a large percentage of the farepaying market.

12. Why do Operators Offer Reduced Fares?

- 12.1 The reasons why operators offer reduced fares to certain categories of passenger are twofold:
- Custom and practice and
 - Varying elasticity to fares among different groups.
- 12.2 Charging reduced fares to children (with various age definitions of 'child') has been established practice since the early twentieth century. While the level of discount has often changed, together with the age limit, the principle is still adopted fairly universally.
- 12.3 Disregarding the large number of buses dedicated to school transport, on the conventional bus network schoolchildren frequently create the peak in demand for bus services, both in terms of number of vehicles and seating capacity. The majority also makes comparatively short trips. Therefore the group of passengers creating peak demand contributes only discounted low fares, which seems perverse.
- 12.4 While all groups of paying passengers react negatively to increases in fares and, as a result, any fare increase will lead to fewer passengers, this resistance is rarely at such a level that there will be less revenue after taking it into account.
- 12.5 There has been very little in the way of published study into fares elasticity in recent years. However, there is no doubt that certain categories of passenger react more negatively to fare increases than others:
- Young people – whose disposable income tends to be lower and for whom fare increases appear disproportionately large;
 - Commuters – where, for example, the market for weekly tickets is very distinct from that of less regular travellers. As such the discount applied when comparing single fares with weekly ticket prices tends to be large. Note also, for example, the focus on price increases for heavily-discounted season tickets whenever national rail fares rise.
- 6.6.8 The aim is therefore to cross the point where the fare reduction produces more revenue than the status quo.

13. Multi-Operator Tickets

- 13.1 Multi-operator tickets must comply with relevant competition legislation. Specific exemption from some of the provisions of the Competition Act 1998 has been made for operators (and LTAs) to jointly set prices of specific statutory ticket types as set out in s134c-138 of the Transport Act 2000 and of

those set up by voluntary agreement or by Qualifying Agreement as revised in the 2008 Local Transport Act. Guidance is contained in:

Public Transport Ticketing Schemes Block Exemption Guidance: CMA53 Sept 2016; and Transport Ticketing Schemes: What's Allowed under Competition Law CMA53(a) Sept 2016.

- 13.2 While it may initially appear to be counter-intuitive, in fact the Competition and Markets Authority favours the availability of multi-operator tickets as it sees these as a way of making it easier for new entrants to come into the market. In its 2011 investigation into the bus industry it was concerned about the low level of availability of multi-operator tickets in some areas. Progress since then has been limited.
- 13.3 The types of tickets covered by statutory schemes are defined in s134C of the 2000 Act as amended by s7 of the Bus Services Act 2017:
- a) tickets entitling the holder to make more than one journey on particular local services or on local services of a class specified in the scheme (whether or not operated by the same person),
 - b) tickets entitling the holder to make a particular journey on two or more local services (whether or not operated by the same person),
 - c) where a particular journey could be made on local services provided by any of two or more operators, tickets entitling the holder to make the journey on whichever service the holder chooses, and
 - d) tickets entitling the holder to make a journey, or more than one journey, involving both travel on one or more local services and travel by one or more connecting rail or tram services.
- 13.4 Any ticket scheme may be for:
- tickets that are valid for a specified period, and
 - tickets that are valid only in a specified area.
- 13.5 The arrangements in an advanced ticketing scheme may include:
- (a) provision about enabling tickets to be purchased or fares to be paid in particular ways,
 - (b) provision about the persons from whom tickets may be purchased or to whom fares may be paid,
 - (c) provision about enabling entitlement to travel to be evidenced in particular ways,

- (d) provision about providing information about the arrangements to the public,
- (e) provision about publicising local services, fares or ticketing arrangements provided or made available by any operator of a local service of a class specified in the scheme, and
- (f) provision as to the appearance of tickets.

13.6 Note that there is no *requirement* to make separate provision for different types of farepaying passenger at different charging rates, but this can be agreed as part of the scheme. However, there are many multi-operator tickets which only exist in adult (full price) form.

13.7 The bodies able to make ticketing schemes under these provisions are not the Travel Concession Authorities (TCAs) but Local Transport Authorities (LTAs) and the list was amended in 2019 to include the addition of Transport for the North.

13.8 Under the original terms of the Transport Act 2000, statutory ticketing schemes could only be made in relation to bus services. The Bus Services Act 2017 amended this to include relevant rail and tram services.

13.9 The majority of the major multi-operator schemes are administered and run by a dedicated ticketing company with the board usually comprising an independent chair, bus company representatives and an LTA representative. It must also be noted that statutory ticketing schemes are rare. The norm is to reach voluntary agreement.

14. Railway Concessions and Reduced Fares

14.1 Concessionary fares on the railway are also divided into statutory and voluntary schemes. The Railways Act 1993, as amended, included provision for the Secretary of State to specify which railcard schemes franchised operators MUST participate in (the statutory schemes). Voluntary schemes differ only in that they are not specified or referred to the Secretary of State prior to introduction.

14.2 Section 28(3) of the Act, as amended, requires that all TOCs participate in certain approved discount card schemes for young and student travellers, disabled passengers and those aged over 60. All TOCs are obliged to participate in such schemes under the terms of their franchise agreements. All other rail cards, including the Network Card, are commercial or voluntary schemes.

14.3 The mandatory schemes are:

- Young Persons (16-25) Railcard (for young people aged between 16 and 25 and students in full time education);

- Senior Railcard (for those over the age of 60); and
- Disabled Persons Railcard (for those with severe disabilities).

14.4 The Ticketing and Settlement Scheme Council at the Rail Delivery Group is responsible for the administration of all the national cards, both mandatory and voluntary. The Council in turn elects a scheme management group to undertake the majority of the work. The primary agreements in relation to railcards were signed in July 1995⁸.

14.5 The Council agrees the conditions of the schemes and they then have to be approved by the Secretary of State. Subject to certain minor variations, the schemes are standard in form. All participants in the schemes are required to sell, honour and otherwise operate the relevant railcards.

14.6 Also under the 1993 Act, TOCs are also required to participate in any local authority's concessionary fare scheme *providing* there is no loss to the train operator.

14.7 The voluntary schemes are:

- Family & Friends railcards;
- Forces Railcards;
- the Network Card (which covers the south-eastern region of England and is confined to passenger operators serving that area);
- 26-30 Rail Card
- GroupSave and
- the Two Together railcard, for two named people travelling together aged 16 or over plus
- The 16-17 Railcard introduced in September 2019.

14.8 The voluntary discount card schemes operate on similar principles to the mandatory card schemes and the national schemes are governed by the same Scheme Council, but unlike the mandatory card schemes, decisions need not be referred to the Secretary of State for prior approval.

14.9 Further detail on rail fares is contained in:

House of Commons Library Briefing Paper SN01904 "Rail Fares and Ticketing" 23 February 2017.

⁸ https://www.raildeliverygroup.com/files/Publications/services/rsp/TSA_V10.1_Main_Agreement_Volume_1.pdf